

Cooling Water Treatment Controller Model: DIGICHEM-ORP-XP2

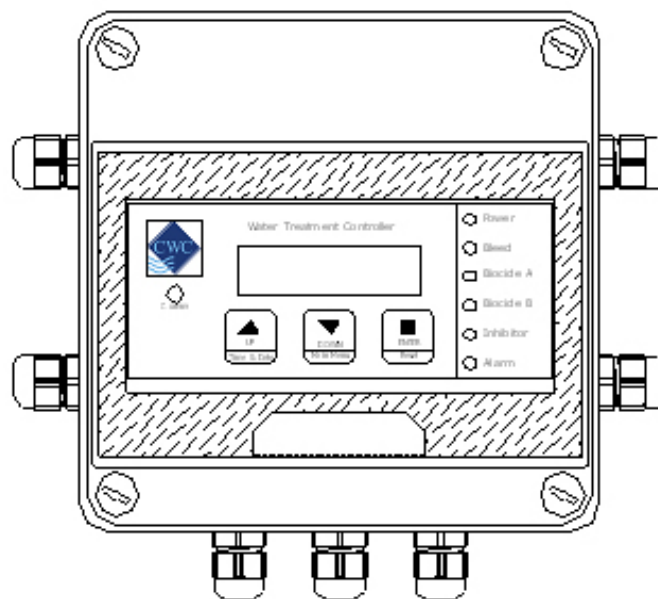

Fill in serial
number here



Refer to
back page

Supplied by:

Convergent Water Controls Pty Ltd

2/4 Huntley Street, PO Box 7058
Alexandria NSW 2015

t: (02) 9698 3131

f: (02) 9698 3210

w: cwc.com.au

e: support@cwc.com.au

Manufacturer: Convergent Water Controls Pty Ltd, Sydney Australia.

Note: On-going product development at Convergent Water Controls may lead to changes in the specifications of this product.

Warranty: This product is guaranteed for a period of 12 months from installation date or 18 months from Invoice date (whichever occurs first). The warranty applies to manufacturing or component defects which may cause the unit to malfunction under specified conditions. The guarantee does not cover damage due to abuse, tampering or improper installation.

Disclaimer: Convergent Water Controls will not be held liable for any consequential damage or loss arising resulting from product malfunction.

Table of Contents

1. Introduction	5
2. Installation	5
2.1 Electrical Wiring	6
2.2 Conductivity Probe Installation & Maintenance	8
2.3 ORP Probe Installation & Maintenance	8
3. Controller Functionality	9
3.1 Menu Logic	9
3.2 Pushbuttons	10
3.3 LED Indication	11
3.4 Comms Port	11
4. Commissioning	12
4.1 Start-Up	12
4.2 Setting Time & Date	13
4.3 μ S/TDS Calibration	14
4.3.1 Slope Calibration	14
4.3.2 Zero Calibration	15
4.3.3 Calibration Reset	16
4.4 ORP Calibration	16
4.4.1 Entering Calibration Mode	16
4.4.2 Slope Calibration	17
4.4.3 Zero Calibration	18
4.4.4 Calibration Reset	19
4.4.5 Exiting Calibration Mode	19
4.5 Testing Relay Outputs	20
4.6 Manual Dose	21
4.7 Factory Settings	22
5. Programming Setup Menu	23
5.1 Set μ S/TDS Units	23
5.2 Set Bleed Setpoint	24
5.3 Set μ S/TDS Hysteresis	25
5.4 Set Bleed Cycle	25
5.5 Select ORP Operation	27
5.6 Set ORP Setpoint	27
5.7 Set Control Method	28
5.7.1 ON/OFF Control	28
5.7.2 PROPORTIONAL Control	32
5.8 Alarm Parameters	35
5.8.1 μ S/TDS Alarms	36

5.8.1.1 High Conductivity Alarm	36
5.8.1.2 Low Conductivity Alarm	37
5.8.1.3 Bleed Timer Alarm	37
5.8.2 ORP Alarms.....	38
5.8.2.1 High ORP Alarm.....	39
5.8.2.2 Low ORP Alarm.....	39
5.8.2.3 Dose Timer Alarm	40
5.8.3 No Flow Alarm.....	41
5.8.4 Delay On Alarm	41
5.9 Inhibitor Setup.....	42
5.10 Biocide Setup.....	46
5.11 Pre-Bleed Setpoint	53
5.12 Bleed Lock-out Setpoint.....	53
5.13 Auxiliary Output On Timer	54
5.14 Flow Switch	56
5.15 Data Logging	57
6. Factory Settings.....	58
7. Specifications.....	59
8. Service & Technical Support.....	60
9. Maintenance Schedule.....	60

1. Introduction

Designed for cooling tower water treatment, the DIGICHEM-ORP-XP2 electronic controller incorporates the following key features:

- Conductivity bleed control
- ORP ON/OFF or proportional control
- Inhibitor pump dosing control
- Secondary Biocide pump control (via 10 independent 28-day timer programs)
- Data logging
- Tower circulating/condenser pump override facility with delay-off timer
- Programmable alarms with programmable delay-off timer

For ORP control the controller can be programmed to dose either an oxidant, causing an increase in ORP (mV increases), or reductant, causing a decrease in ORP (mV drops). The DIGICHEM-ORP-XP2 measures ORP with respect to a solution ground probe using its differential input amplifier to reduce unstable readings that can be introduced via electrical noise.

2. Installation

Mount the DIGICHEM-ORP-XP2 on a flat vertical surface away from extreme heat, humidity or areas where temperature variations are extreme, ideally at eye-level to allow good visibility of the LCD display. Also ensure that a 240VAC mains power point is located nearby.

Please ensure that IP66, or greater, cable glands or connectors are used for any wiring that penetrates the body of the DIGICHEM-ORP-XP2 controller and that any un-used glands or plugs are adequately plugged or capped to maintain their IP rating and avoid moisture ingress. Failure to do so could void your warranty.

2.1 Electrical Wiring

CAUTION: If opening the controller, pull the lid away from the base slowly to ensure you do not impose any strain on the interconnecting cable, which easily unplugs from the motherboard by gently levering the black locking clips outwards.

NOTES:

1. The BNC connector for the ORP sensor is panel mounted in the bottom of the enclosure
2. The solution ground probe connection point is via a screw terminal on the circuit board (terminal L3)
3. The N/O output R19 & R20 is the condenser pump override relay control.

The diagrams below shows the connections to the DIGICHEM-ORP-XP2 controller circuitry.

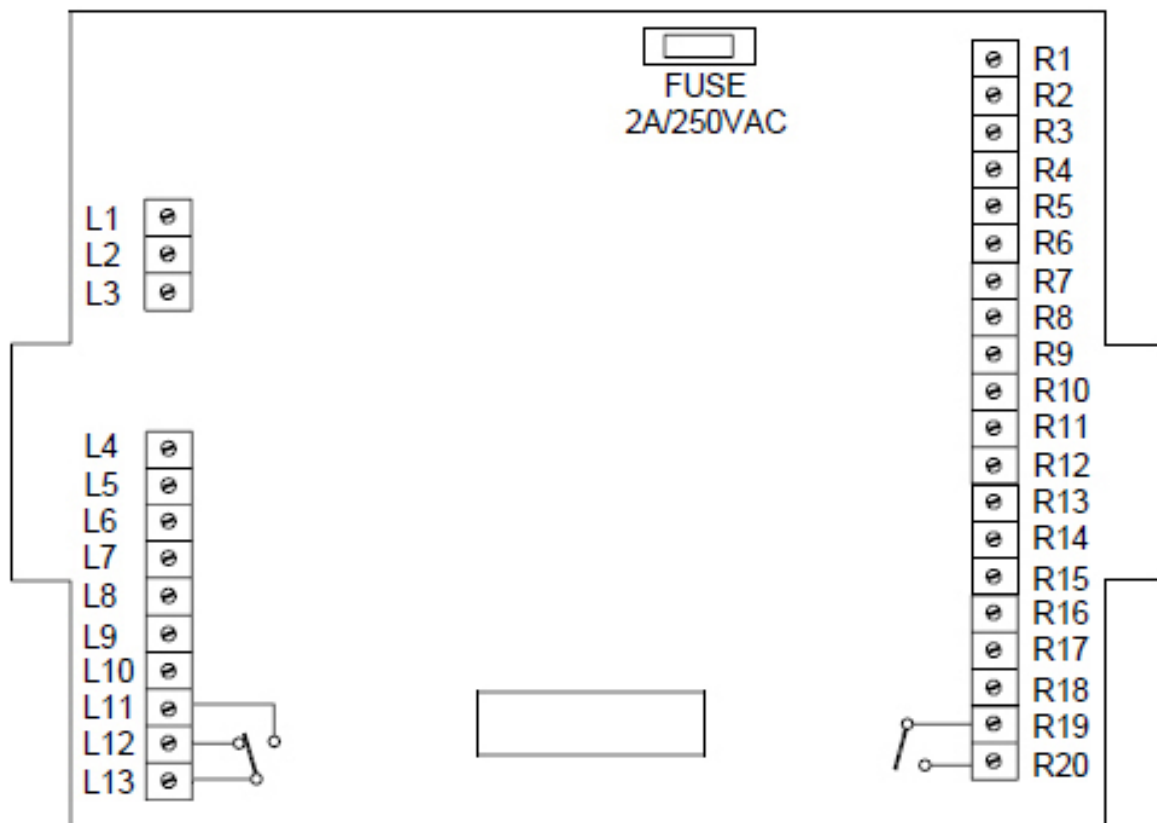

L1:	BNC - ORP Signal (White)
L2:	BNC - common (Green)
L3:	Solution Ground Probe
L4:	Conductivity Probe Cable Screen (Grey)
L5:	Conductivity Probe PR+ (Brown or Red)
L6:	Conductivity Probe PR- (Yellow)
L7:	Conductivity Probe CM+ (Blue)
L8:	Water Meter In
L9:	Flow Switch In
L10:	Flow Switch Common / Water Meter Common
L11 + L13:	Alarm Relay N/O volt-free (10A/250VAC res)
L12 + L13:	Alarm Relay N/C volt-free (10A/250VAC res)
R1:	Mains Active 240VAC (power supply)
R2:	Mains Neutral
R3:	Auxiliary Continuous Active 240VAC (2A fused)
R4:	Auxiliary Neutral
R5:	Solenoid Valve Active 240VAC (2A fused)
R6:	Solenoid Valve Neutral
R7:	Inhibitor Pump Active 240VAC (2A fused)
R8:	Inhibitor Pump Neutral
R9:	Biocide 'A' Active 240VAC (2A fused)
R10:	Biocide 'A' Neutral
R11:	ORP Active 240VAC (2A fused)
R12:	ORP Neutral
R13 - R18:	Common Earth
R19:	Auxiliary Relay common
R20:	Auxiliary Relay N/O volt-free (10A/250VAC res)

Fuse: 2A/250VAC (M205, 20mm x 5mm diameter)

Notes on Alarm Relay Contacts :

1. Alarm relay is energised (ie. L13 connected to L11) during normal operation of the unit.
2. Alarm relay de-energises (ie. L13 connected to L12) when an alarm condition is confirmed or when the unit loses power.

Notes on Flow Switch:

A flow switch with N/O or N/C volt-free contacts are required to be connected to terminals L9 & L10 (not polarity sensitive). The flow switch logic is programmable via the menu.

2.2 Conductivity Probe Installation & Maintenance

The probe is supplied screwed into a PVC Tee piece such that the electrode tips are submerged in the water flowing through the manifold in which the tee is usually fitted. The probe should be positioned with the black markers on the probe aligned with the black markers on the manifold Tee. This ensures that the 2 electrodes of the probe are positioned symmetrically with respect to the direction of water flow. See the photograph and diagrams below:

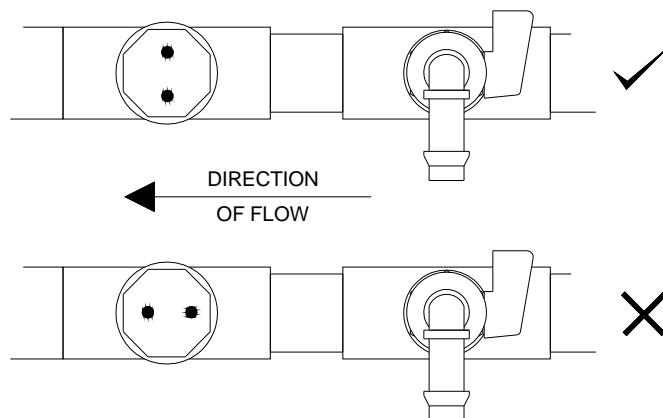

The probe's electrodes should periodically be cleaned to maintain accurate TDS measurements. The frequency of cleaning required will vary from one application to another. In a new installation, it is recommended that the probe be cleaned after 2 weeks of service.

To clean the probe, first unplug the probe lead and unscrew the probe from the manifold. The probe can normally be cleaned using a cloth or paper towel. Occasionally the probe's carbon electrodes may be coated with substances which requires more vigorous cleaning (this coating may not always be visible). To clean a coated electrode, use a fine grit abrasive, such as emery paper. After cleaning, apply more Teflon[®] tape to the probe thread and screw back into the manifold. The controller should always be calibrated after probe cleaning.

2.3 ORP Probe Installation & Maintenance

Consider carefully the type and location of the ORP sensor. Your instrument supplier should be able to advise the correct sensor type for your application. Plan the installation such that the ORP sensor is as close as possible to the controller. If the sensor needs to be located further away from the controller, an extension cable must be obtained. The further the sensor is away from the controller, the greater the effect of electrical interference will be. This may degrade the signal from the sensor and causes incorrect readings. Never attempt to extend the sensor cable by means of a terminal block or soldered connection. This will leave the connection open to interference or moisture, which will affect the accuracy of the system. Always have the connection (when using an extension cable) in a waterproof junction box. A maximum sensor cable length of 25 metres is recommended.

3. Controller Functionality

3.1 Menu Logic

The DIGICHEM-ORP-XP2 has an advanced but very user-friendly menu system:

- The menu structure is circular
- The relevant menu item, or programmed value flashes
- Up & Down arrow pushbuttons allow you to scroll through the menu items and to increase/decrease programmed settings
- The MAIN MENU expands to several levels of SUB MENUS when pressing ENTER on various menu items
- The LCD is backlit

The MAIN MENU of the controller is illustrated as follows:

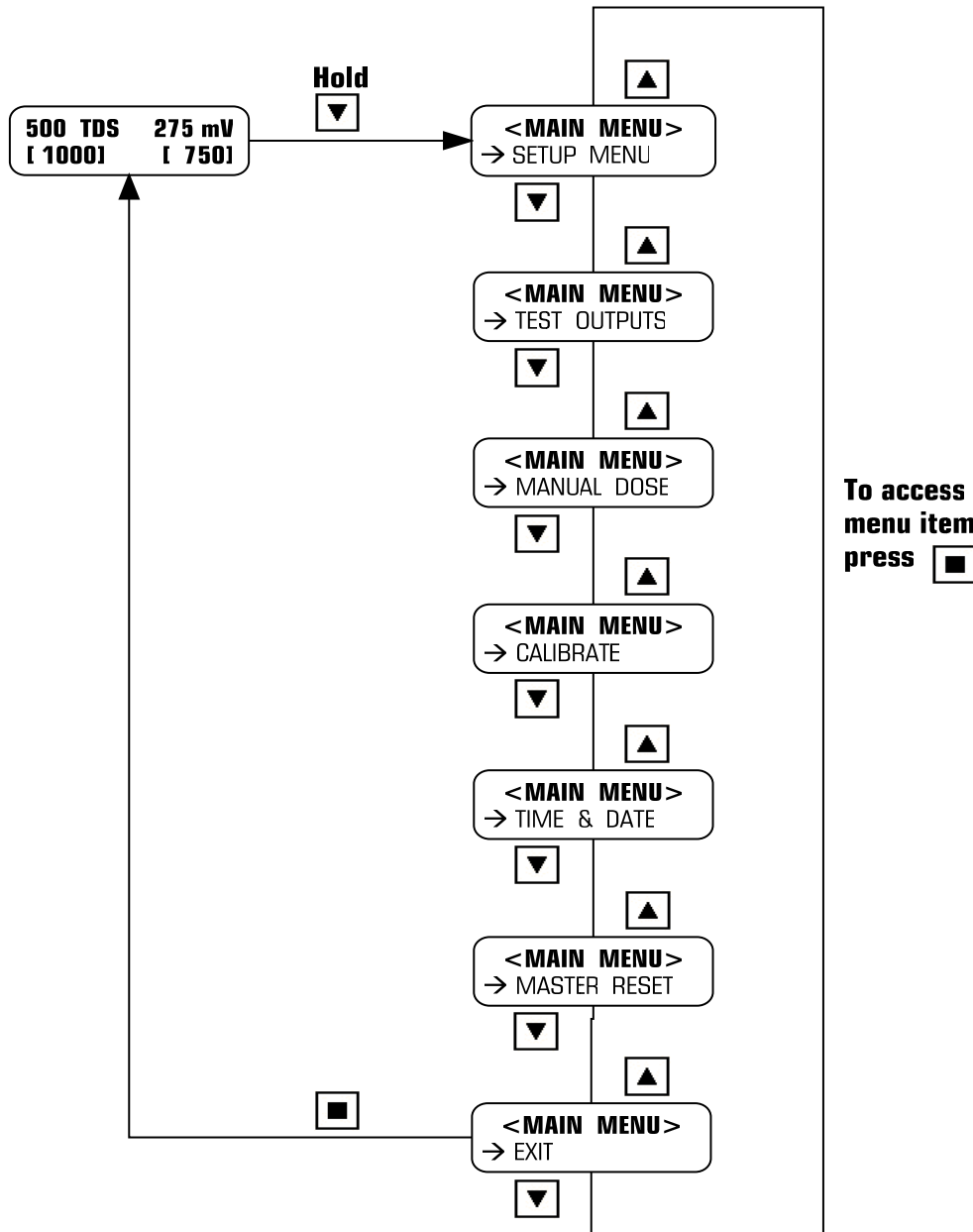

3.2 Pushbuttons

The DIGICHEM-ORP-XP2 has 3 pushbuttons which each have dual functions:

1. Scroll UP (Time & Date)
 2. Scroll DOWN (Main Menu)
 3. ENTER (Alarm Reset)
- The **Scroll UP** and **DOWN** pushbuttons allows you to scroll in both directions in the circular menus. Once a menu item has been selected and there is a value to program, the Scroll pushbuttons allow you to increase or decrease the number programmed.
 - The **ENTER** pushbutton allows you to enter a part of the program that you have selected. It also accepts any numbers programmed with the Scroll pushbuttons.
 - If the Scroll UP (Time & Date) pushbutton is pressed momentarily in NORMAL MODE (explained in section 4.1), the time and date is displayed. To revert back to NORMAL MODE, press the pushbutton momentarily again.

The time and date is displayed as follows:



NOTE:

The Time & Date is programmable, but the Week No is automatically set. Hence, if you have multiple controllers in the field, the Week No will be the same on all (assuming the Time & Date are programmed correctly).

- To get into the menus of the DIGICHEM-ORP-XP2, hold down the Scroll DOWN (Main Menu) pushbutton. The display will count down until you access the menus.
- If you wish to cancel an alarm or any timers activated, from the main display, press and hold the ENTER (Alarm Reset) pushbutton until the display says:

Resetting...

3.3 LED Indication

There are 6 LEDs on the front face of the DIGICHEM-ORP-XP2:

- Power (green): illuminates continuously when power is applied to the controller
- Bleed (amber): illuminates continuously when power is applied to the solenoid output of the controller. If the solenoid output is suspended due to a pause in the bleed cycle, the LED will flash on and off.
- Biocide A (amber): illuminates continuously when power is applied to the Biocide A output of the controller.
- ORP (amber): illuminates continuously when power is applied to the ORP output of the controller. If the ORP output is suspended due to a pause in the dose cycle or no flow, the LED will flash on and off during the ON cycle.
- Inhibitor (amber): illuminates continuously when power is applied to the Inhibitor output of the controller. If the Inhibitor output is suspended due to no flow, the LED will flash on and off during the ON cycle.
- Alarm (red): illuminates when the alarm relay switches. If the alarm delay is timing before the alarm condition is confirmed, the LED will flash on and off.

3.4 Comms Port

There is a Comms port on the front panel of the controller next to the LCD. This is used to download data from the controller, and can also be used to upload new software versions should they be required.

The data is downloaded via the Comms port on the front panel of the controller. An optional cable is required, P/N SP-XP2-COMCABLE-1, to perform a direct download to a pc or laptop.

However, some computers or laptops do not have a serial port, so a USB to serial adapter will be required. These can be purchased from any electronics store, or through CWC. Our part number: HOBO CABLE-USB-232. The brand "Keyspan" is recommended.

4. Commissioning

CAUTION: Refer to previous section before reading this section

4.1 Start-Up

Power up the controller after installation. After a start-up sequence, the controller automatically goes into NORMAL MODE. The display should read the measured conductivity and ORP as well as the conductivity Setpoint (which alternates with the temperature measured by the conductivity probe) and ORP Setpoint within square brackets as follows:

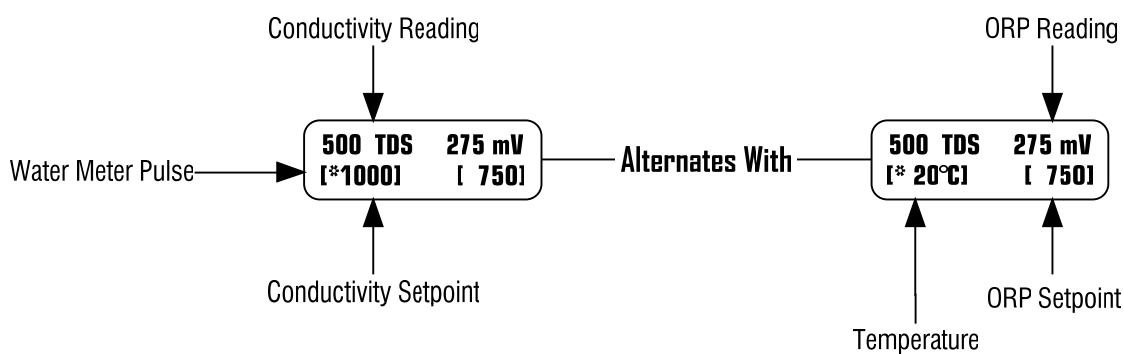

NOTE: An asterisk '*' flashes on the screen when the controller receives a pulse from an optional water meter.

Other information that you may see on the display, which alternates with the display above:

- When an alarm is reported, the actual alarm message will be periodically displayed, e.g.



- When a flow switch is connected to the controller, each output is suspended when there is no flow past the flow switch, if the output is selected via the Flow Switch Menu.



4.2 Setting Time & Date

Main Menu > *TIME & DATE*

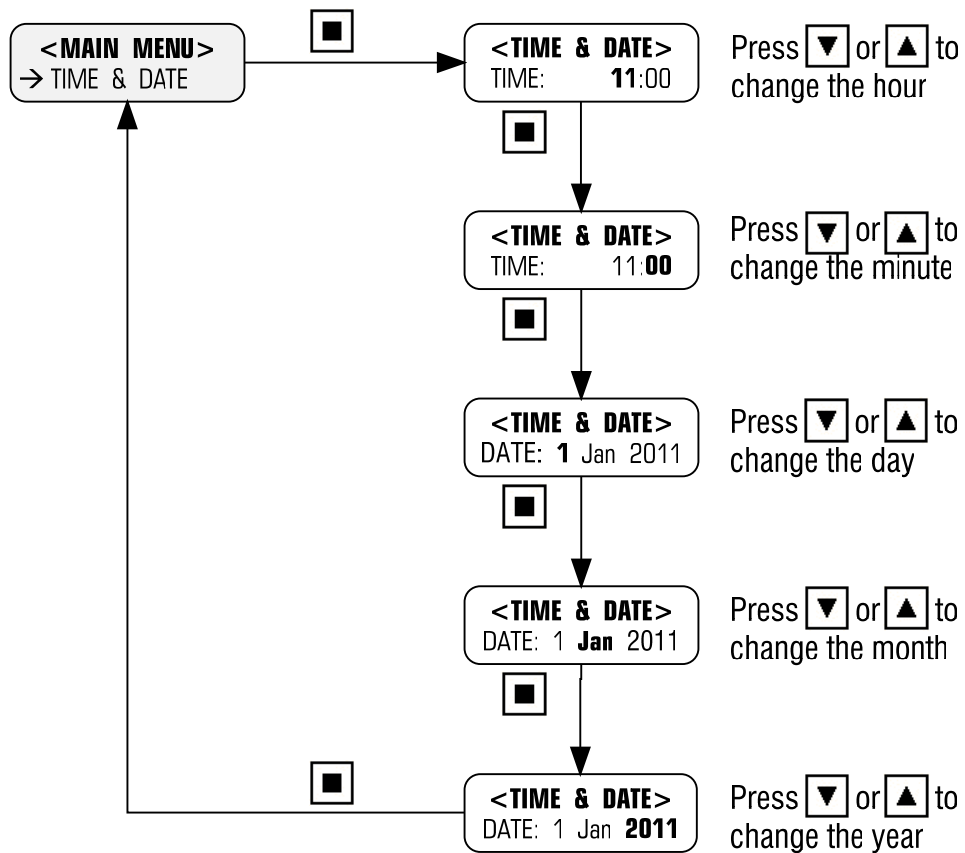

NOTE: The Week No will be automatically set

4.3 μ S/TDS Calibration

IMPORTANT: Select the display in either μ S or TDS before proceeding.
(Refer section 5.1)

4.3.1 Slope Calibration

Main Menu > CALIBRATE > CALIB. μ S/TDS

Take a sample of water from the sample valve on the manifold and measure the conductivity with a hand-held conductivity meter. Alternatively, insert the Conductivity probe in a buffer solution of known conductivity. Should the conductivity readout on the display differ from the sample taken, calibrate the controller as follows:

Adjust the current reading via the Calibration Menu to the desired reading.

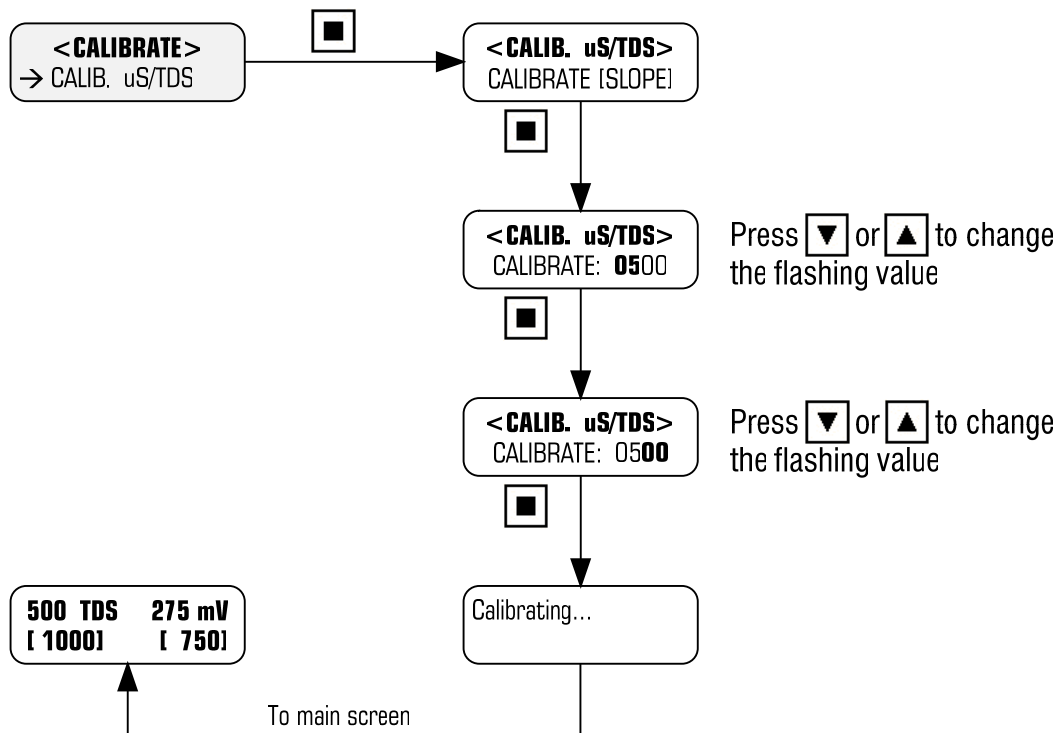

4.3.2 Zero Calibration

The zero is factory set so should not require calibration. However, if the display reads above zero with the conductivity probe disconnected, recalibrate the zero as follows:

1. Remove the probe from the manifold.
2. Dry the electrodes of the probe, so that there is zero (or minimal) conductivity between the electrodes.
3. Wait until the reading on the LCD is stable. If the reading does not settle to exactly 0, wait until it does not drop any further.
4. Go into the Calibrate Menu and set the Zero Calibration (see below).
5. Screw the probe back into the manifold.
6. Perform the SLOPE calibration again.

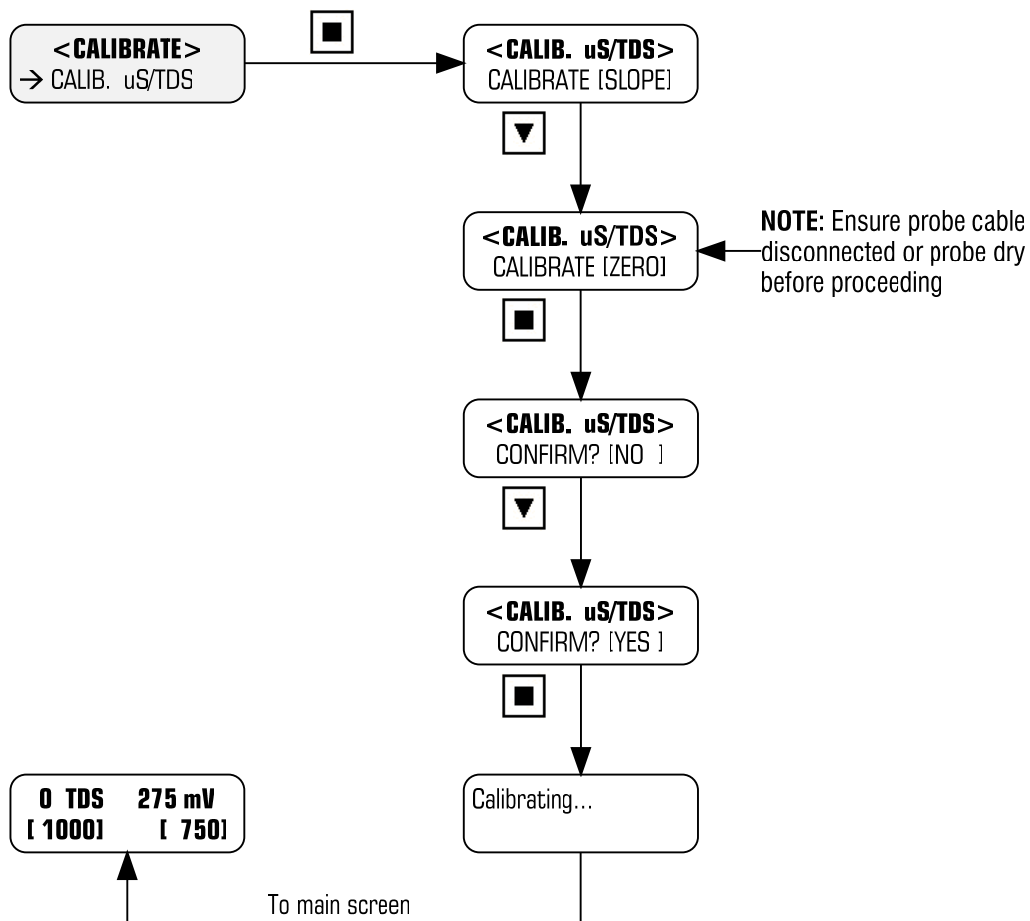

4.3.3 Calibration Reset

If you inadvertently calibrate the zero and/or slope to the incorrect values, and you cannot recover by repeating the normal calibration procedure, then you can reset the calibration and start again.

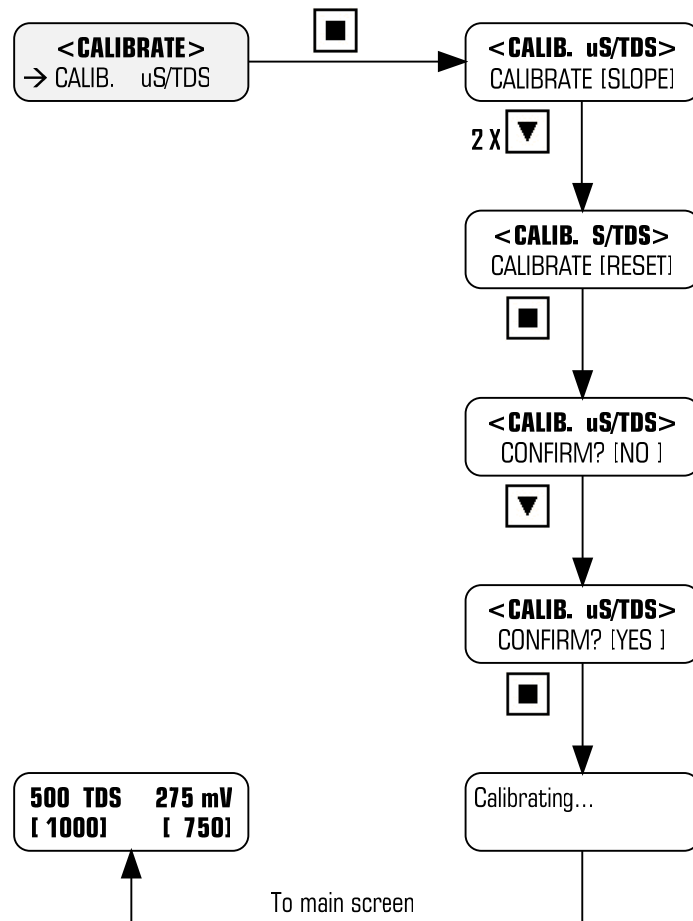

4.4 ORP Calibration

NOTE: The DIGICHEM-ORP-XP2 is factory calibrated, so under normal circumstances, calibration is not required. However, if you need to calibrate, or verify the reading in buffer solutions, proceed as follows:

4.4.1 Entering Calibration Mode

Putting the controller into CALIBRATE mode bypasses the solution ground probe. This enables you to use a mV simulator connected to the controller, or enables you to insert the ORP sensor in a buffer solution without the solution ground probe. This ensures you get an accurate reading on the controller.

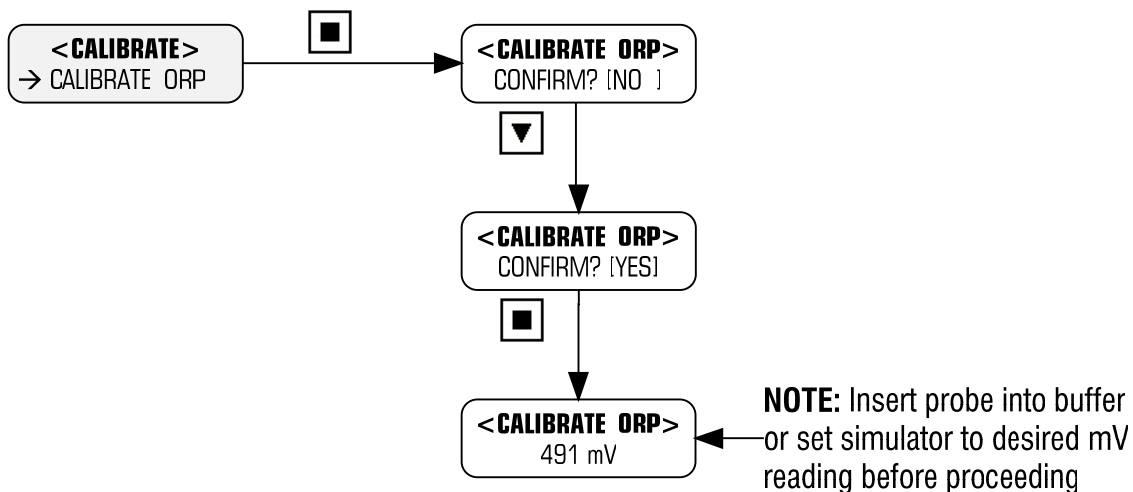

4.4.2 Slope Calibration

Before you proceed, set the mV simulator to the desired setting, or put the ORP sensor in the buffer solution.

IMPORTANT: Wait for the measured mV reading to stabilise before proceeding.

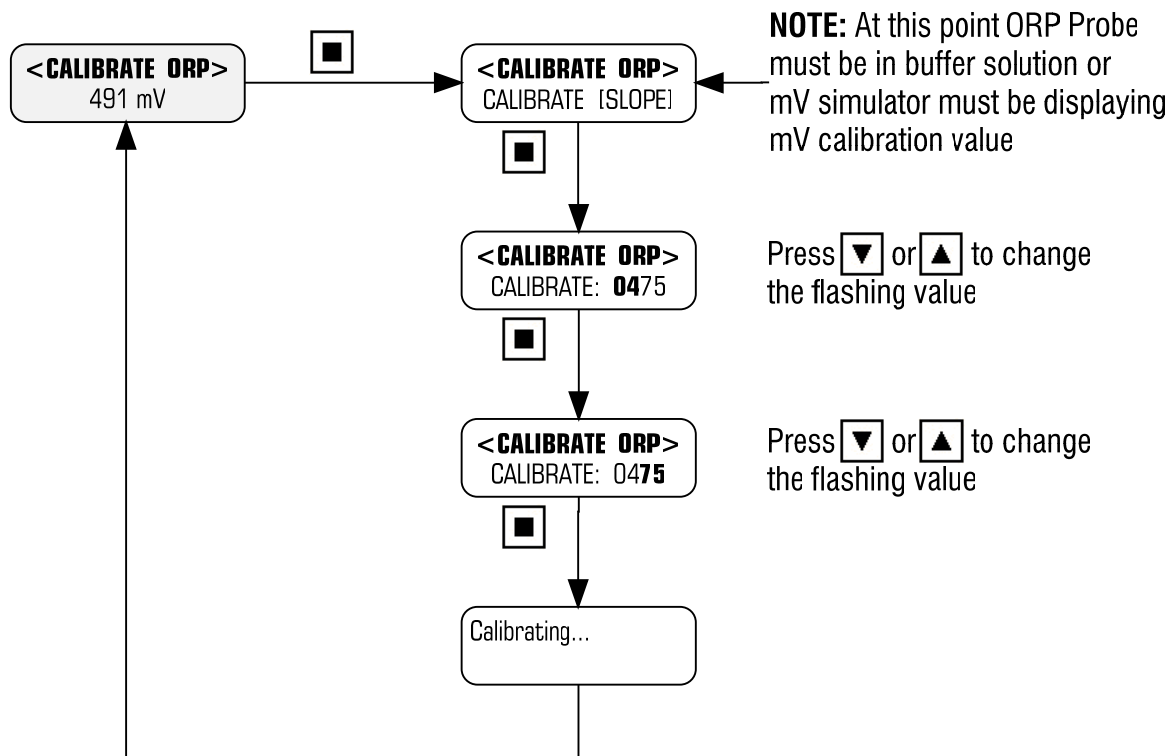

4.4.3 Zero Calibration

The zero is factory set so should not require calibration. However, if you want to set the zero, you will require a mV simulator with a 0mV or pH7 setting. Alternatively, you can short circuit the BNC input for this procedure.

Before you proceed, set the mV simulator to the zero setting (pH7 setting = 0mV)

IMPORTANT: Wait for the measured mV reading to stabilise before proceeding. This reading should be very close to zero.

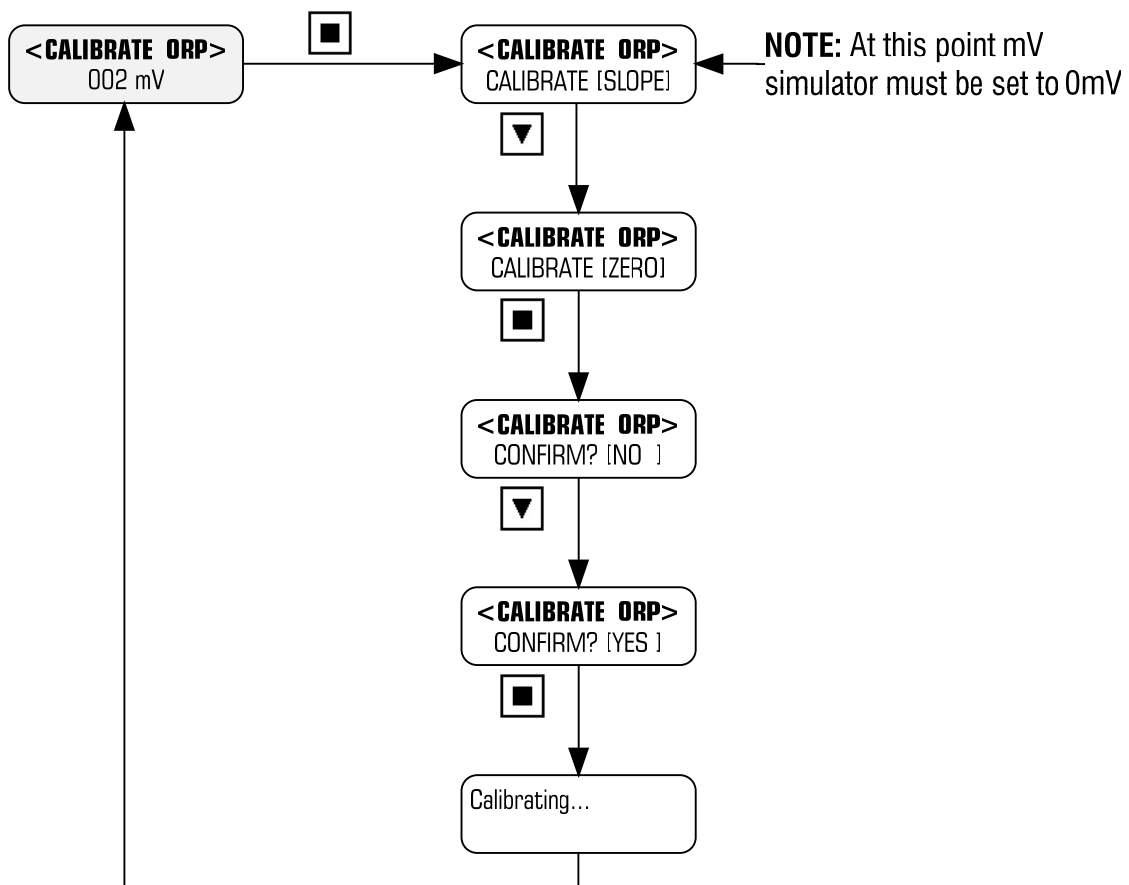

4.4.4 Calibration Reset

If you inadvertently calibrate the zero and/or slope to the incorrect values, and you cannot recover by repeating the normal calibration procedure, then you can reset the calibration and start again.

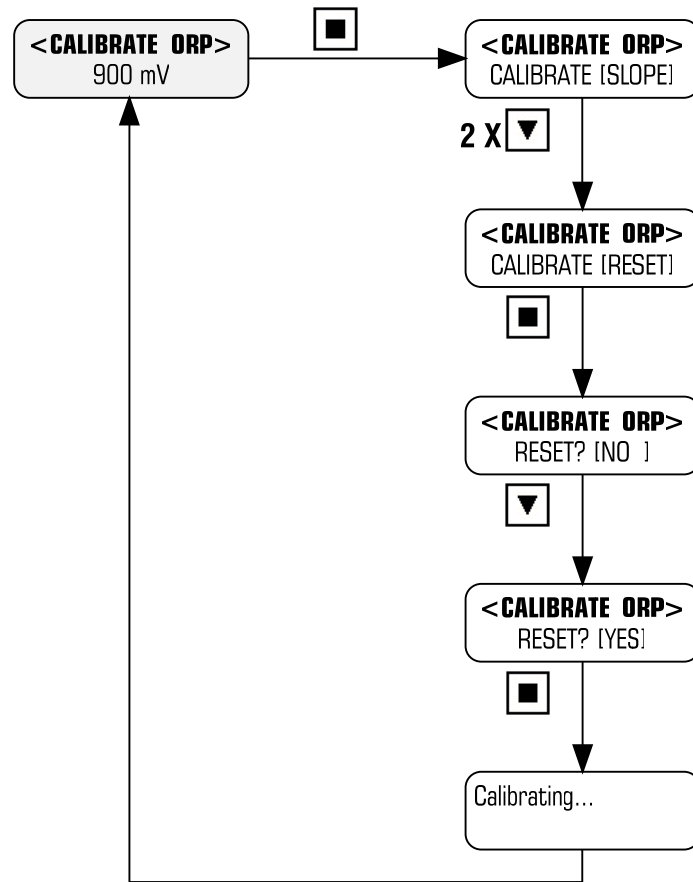

4.4.5 Exiting Calibration Mode

Once calibration is complete, or you have finished verifying your ORP measurements in buffer solutions or with a mV simulator, you will need to exit CALIBRATE mode in order for the solution ground probe to become active again. Proceed as follows or simply leave the controller and it will revert back to NORMAL mode after a few minutes.

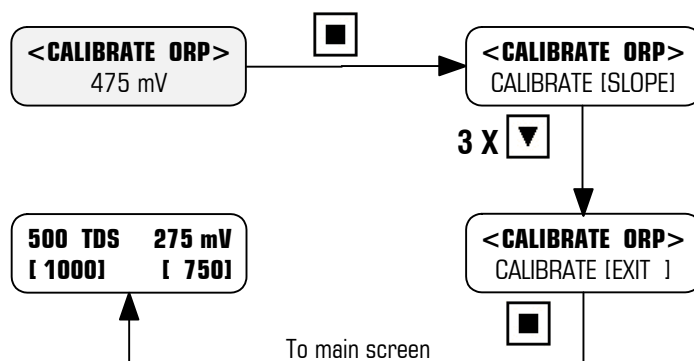

4.5 Testing Relay Outputs

Main Menu > *TEST OUTPUTS*

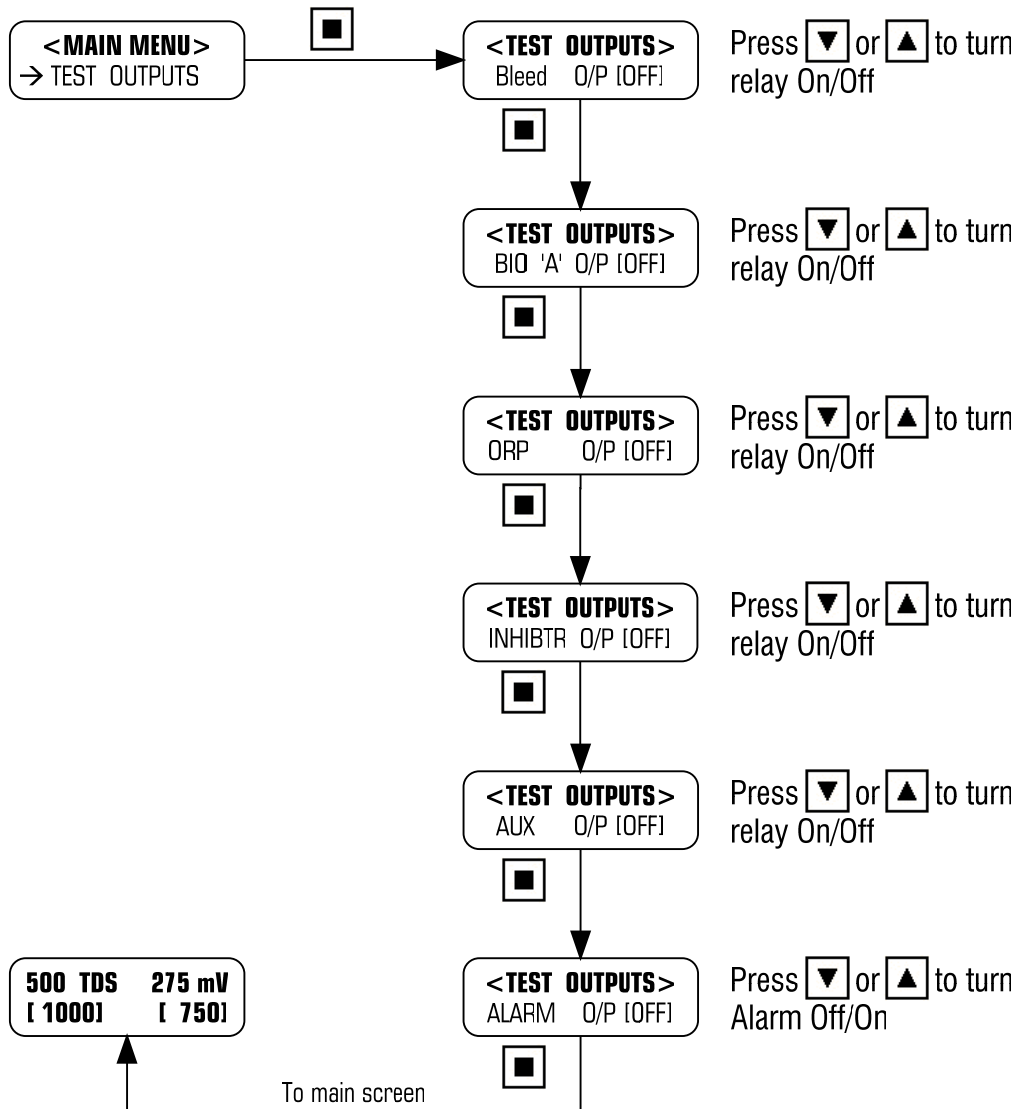

When any of the Outputs is activated, the respective Output LED illuminates and the Output relay switches, putting 240VAC power onto the output terminal, which activates the pump or solenoid valve wired to it.

When the Alarm Output is activated, the red Alarm LED illuminates and the relay de-energises, switching the Common from the Normally Open Contact to the Normally Closed contact of the Alarm relay.

NOTES:

1. If any output is activated manually without reverting back to the deactivated state, the controller will automatically turn the output off 2 minutes after no pushbutton activity.
2. If you wish to drive an output for longer than 2 minutes, activate the MANUAL DOSE function within the MAIN MENU (Refer to section 4.6)
3. The outputs should all switch on when tested, regardless of the flow condition.
4. Do not switch the Aux O/P On relay rapidly ON and OFF, if powering the condenser pump of the cooling tower.

4.6 Manual Dose

Main Menu > MANUAL DOSE

To perform an unattended slug dose of chemical, simply program the dose time (up to 99 minutes, in 1 minute increments) as follows:

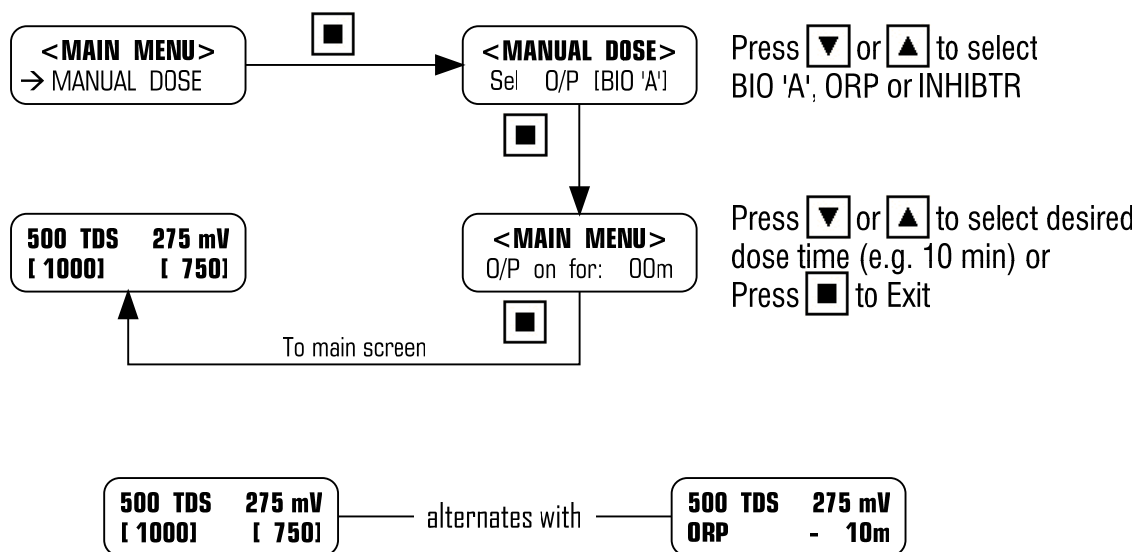

Notes:

- To cancel a manual dose, press and hold the ENTER (Alarm Reset) pushbutton
- The display counts the manual dose time down to zero.
- Manual dose operates regardless of flow status.

4.7 Factory Settings

Main Menu > FACTORY SETTINGS

CAUTION:

- Enter this part of the program ONLY if you wish to erase your program settings.
- The default settings (listed in Section 7 of this manual) most likely will not suit your application, so it will be necessary to reprogram the controller with your desired settings.
- This menu gives the option of resetting the calibration as well.

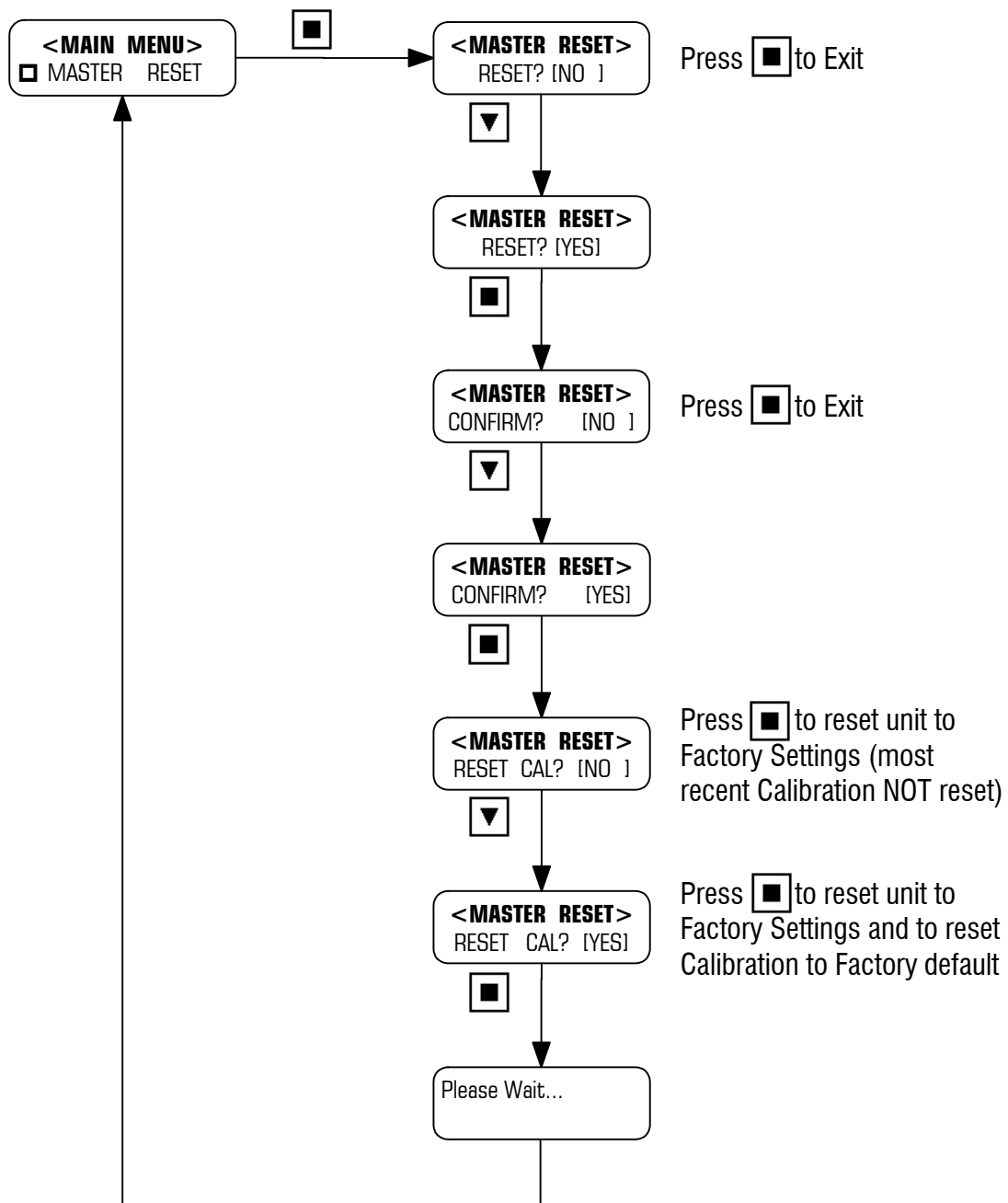

5. Programming Setup Menu

Main Menu > SETUP MENU

IMPORTANT:

- Once settings are changed, it is necessary to exit the SETUP MENU in order to save your settings.
- Setup Menu Structure illustrated as follows:

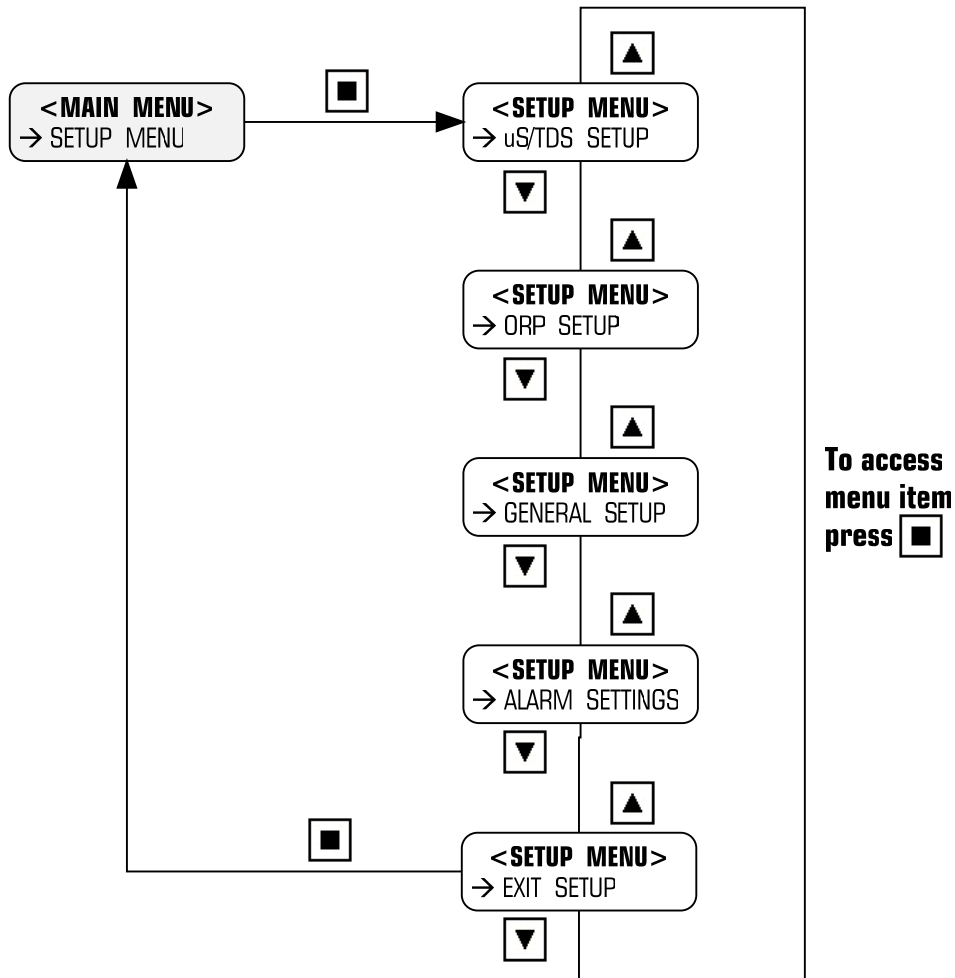

5.1 Set μ S/TDS Units

Main Menu > SETUP MENU > μ S/TDS SETUP > UNITS

Conductivity can be displayed in either:

- TDS (Total Dissolved Solids), or
- μ S (Microsiemens/cm)

Note: The displayed units should be selected before performing any calibration or programming of the unit.

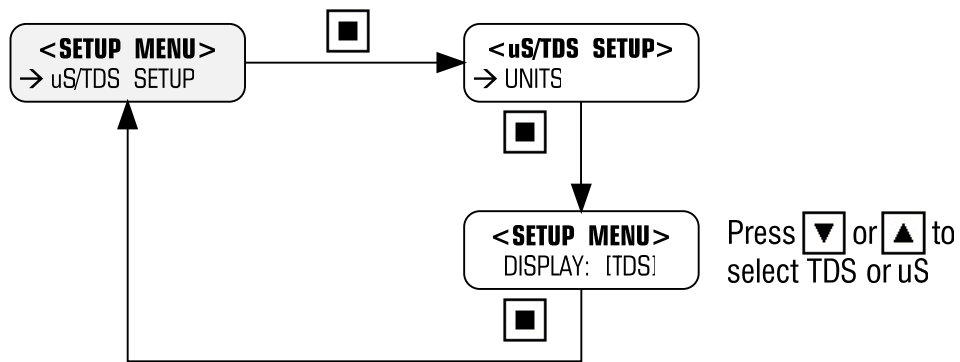

5.2 Set Bleed Setpoint

Main Menu > SETUP MENU > μS/TDS SETUP > BLEED SETPOINT

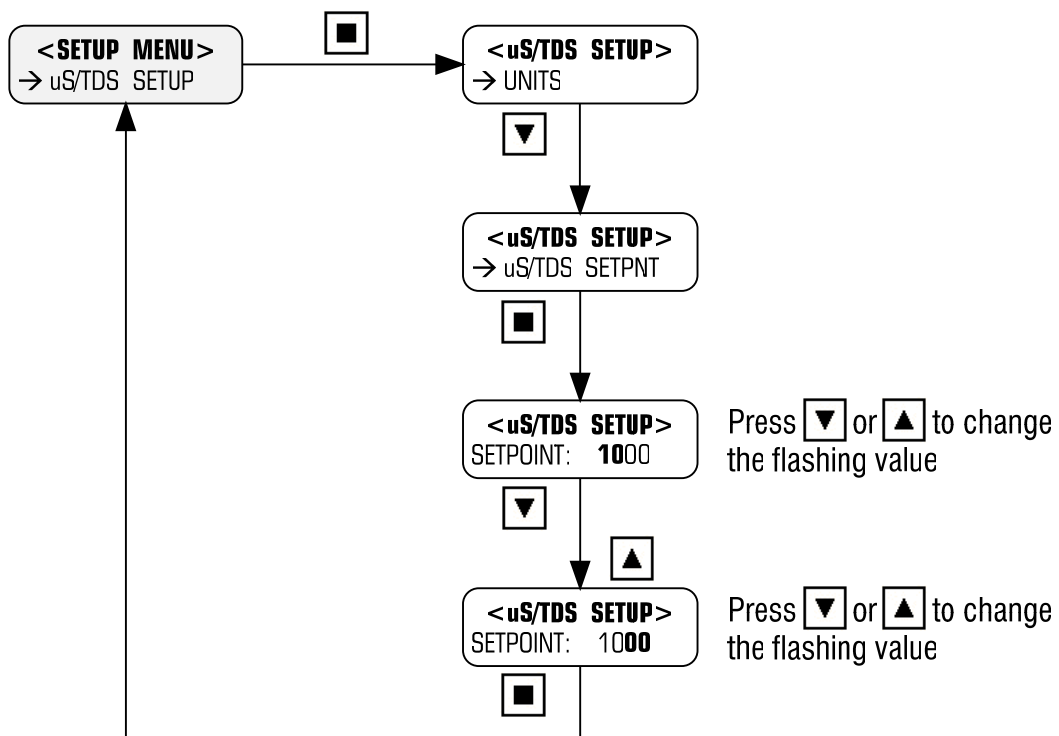

The Bleed Setpoint is the desired conductivity value of the process (displayed in TDS or μ S). When a solenoid valve is connected to the bleed output, the valve opens when the conductivity rises above the setpoint. When this occurs, the tower water is flushed to drain and fresh make-up water dilutes the system, thus lowering the conductivity of the tower water. The valve shuts when the conductivity drops to the hysteresis value (explained in the next section). The cycle repeats.

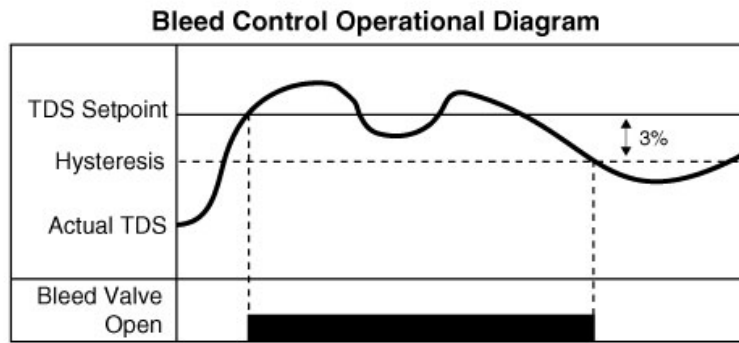

5.3 Set μ S/TDS Hysteresis

Main Menu > *SETUP MENU* > μ S/TDS SETUP > *HYSTERESIS*

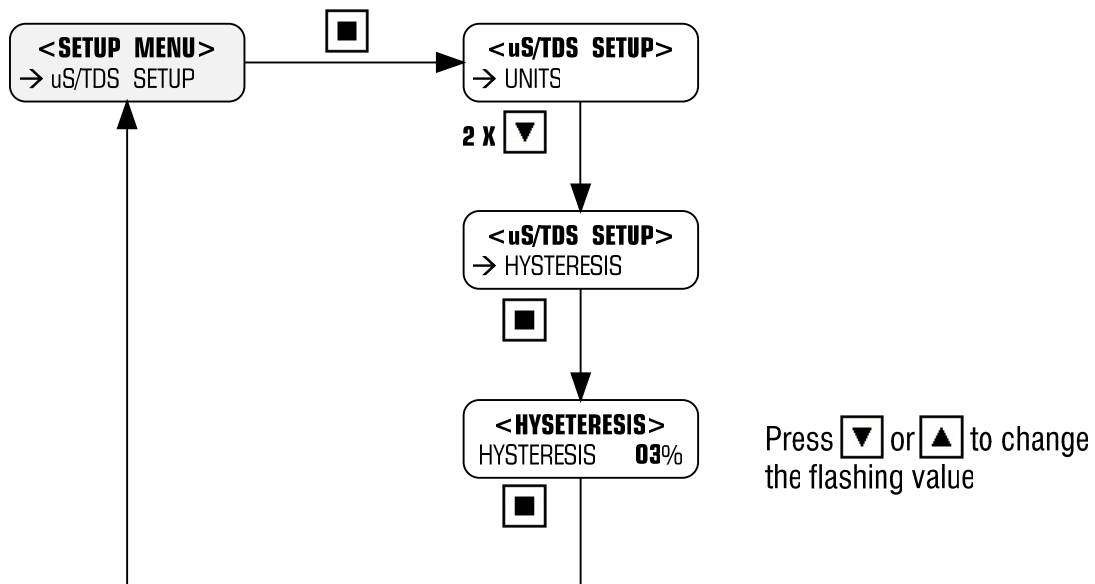

Hysteresis is the deadband between the two conductivity points at which the solenoid valve opens and closes. The solenoid valve opens when the conductivity rises above the programmed setpoint and shuts when it drops to a level below the setpoint. This level is called Hysteresis and is a % of the setpoint.

5.4 Set Bleed Cycle

Main Menu > *SETUP MENU* > μ S/TDS SETUP > *BLEED CYCLE*

When the controller calls for bleed, the solenoid valve can be programmed to bleed continuously or on a cycle until it reaches the Conductivity Setpoint. To leave the Bleed Cycle in its disabled state, proceed to the next section. If you wish to program a bleed cycle, then proceed as follows:

The menu asks for a Bleed Time and a Wait Time to be programmed. The Wait Time follows the Bleed Time, and the cycle is repeated until the Setpoint minus hysteresis is reached.

A bleed cycle can prevent excessive tower drainage in a very small system and allows the make-up to efficiently mix with the cooling tower water.

The ability to cycle is also useful because it prevents flooding by slowing down the bleed flow rate into a blocked drain.

The following diagram illustrates a bleed cycle programmed for a 10 second bleed off followed by 40 second wait:

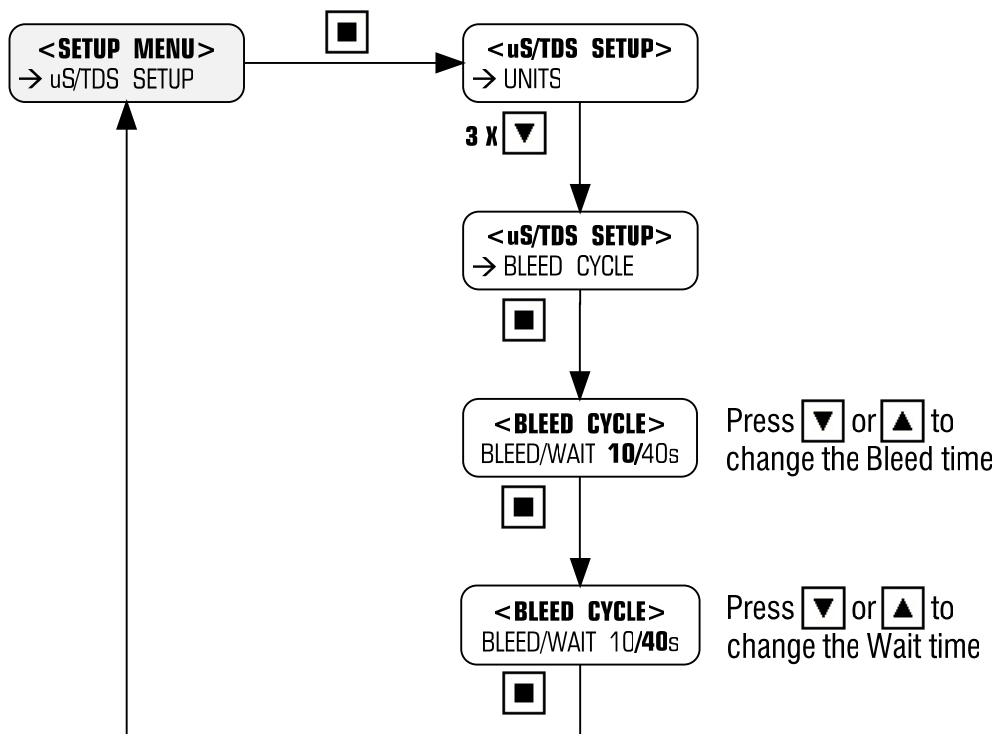

In the example above, the solenoid bleeds 10 seconds during every 50 second cycle (ie 10+40), which equates to a 20% bleed cycle.

If you wish to have the control output continuously active during bleed (rather than cycling ON and OFF), simply set the Bleed/Wait times to 00/00s

Note: If the conductivity is greater than 25% above the programmed setpoint, then the controller automatically adjusts the ON/OFF bleed cycle to bring it to setpoint more quickly.

5.5 Select ORP Operation

Main Menu > SETUP MENU > ORP SETUP > OPERATION

The DIGICHEM-ORP-XP2 controller can dose either an oxidant (eg.) to increase the ORP, or a reductant (eg.) to decrease the ORP. Only one or the other can be selected:

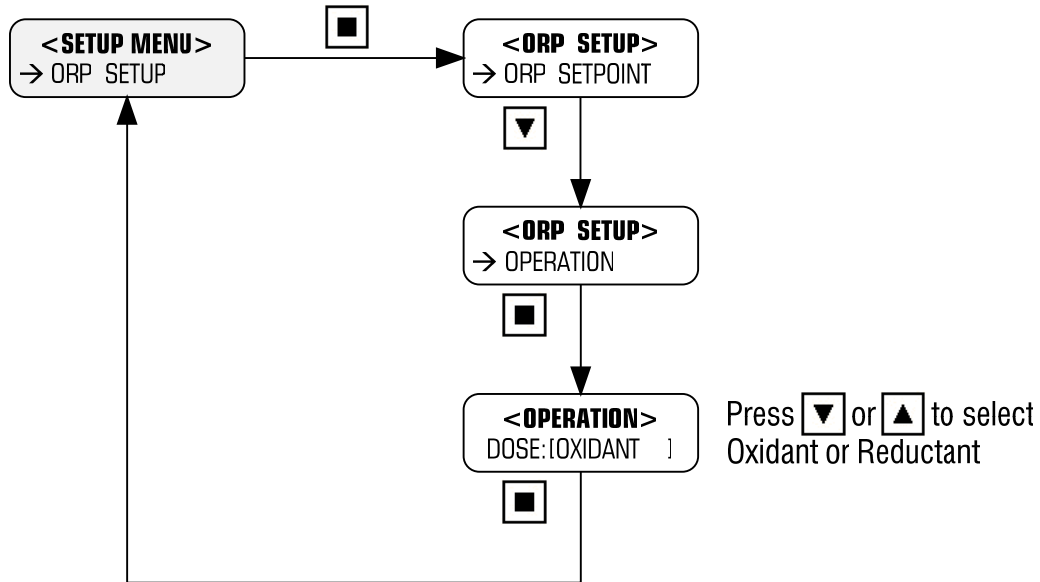

5.6 Set ORP Setpoint

Main Menu > SETUP MENU > ORP SETUP > CONTROL SETPOINT

The ORP Setpoint is the desired ORP value of the process (displayed in mV).

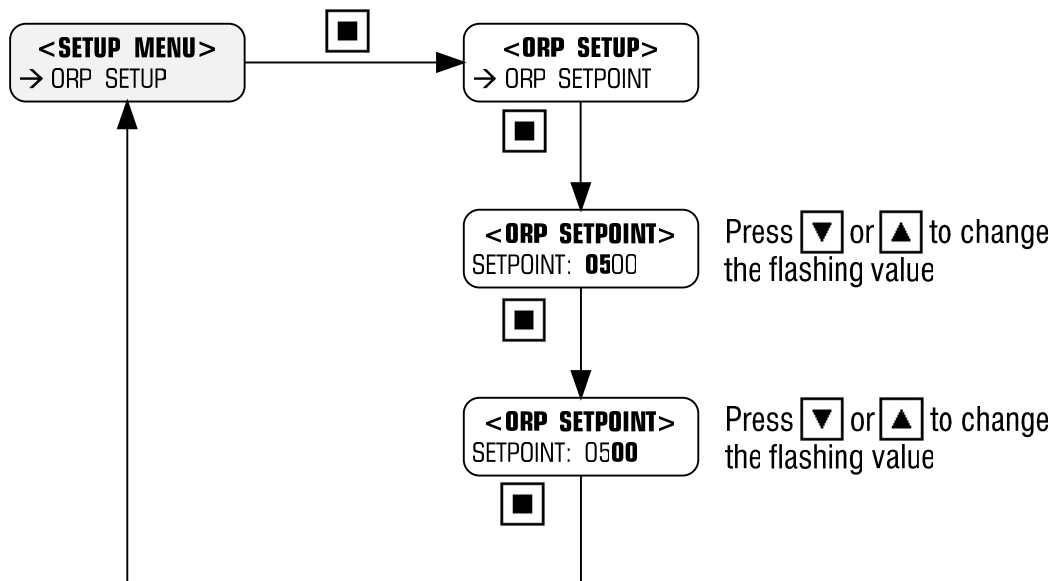

5.7 Set Control Method

Main Menu > SETUP MENU > ORP SETUP > CONTROL METHOD

The DIGICHEM-ORP-XP2 features 2 methods of ORP control:

- **ON/OFF control** with programmed Dose Cycle (ie modulation), or
- **PROPORTIONAL control** via automatically varying duty cycle

With **ON/OFF control**, the controller either turns the pump on continuously when correcting the ORP or modulates the pump by turning the pump ON and OFF during the dosing period. The On period and Off periods are programmable.

With **proportional control**, the dosing algorithm modulates the pump based on a percentage ORP variation from the Setpoint. The further the ORP is from the Setpoint, the shorter the OFF period is with respect to the ON period. The closer the ORP is to the Setpoint, the longer the OFF period is with respect to the ON period. The control cycle and the proportional band are programmable.

5.7.1 ON/OFF Control

If **dosing oxidant**, the pump will dose when the ORP readout drops below the ORP SETPOINT . Dosing will stop once the readout rises above the ORP SETPOINT plus the Hysteresis percentage. (This percentage is the Hysteresis value and is a percentage of the SETPOINT). Cooling tower applications require dosing an Oxidant to increase the ORP.

If **dosing reductant**, the pump will dose when the ORP readout rises above the ORP SETPOINT . Dosing will stop once the readout drops below the ORP SETPOINT minus a percentage. (This percentage is the Hysteresis value and is a percentage of the SETPOINT).

Hysteresis prevents rapid switching of the pump on and off when the system ORP hovers around the Setpoint. Hysteresis is the difference between the two mV points at which the pump starts and the pump stops.

Hysteresis is programmed as a percentage of the Setpoint, is only applicable to ON/OFF control, and is usually only required to be greater than 1% if no dose cycle is programmed.

For example, if the SETPOINT is 500 mV and the Hysteresis value is 5%, then the calculated Hysteresis value is 25 mV.

If dosing oxidant, the pump will be activated when the ORP drops below 500 mV and will stop when the ORP rises above 525 mV (i.e. 500 mV plus 25 mV).

If dosing reductant, the pump will be activated when the ORP rises above 500 mV and will stop when the ORP drops to 475 mV (i.e. 500 mV minus 25 mV).

Once the Setpoint is programmed for ON/OFF control, 2 parameters are required to be programmed:

- Hysteresis, and
- Dose Cycle

Step 1:

Select the ON/OFF Control Method

Main Menu > **SETUP MENU** > **ORP SETUP** > **CONTROL METHOD**

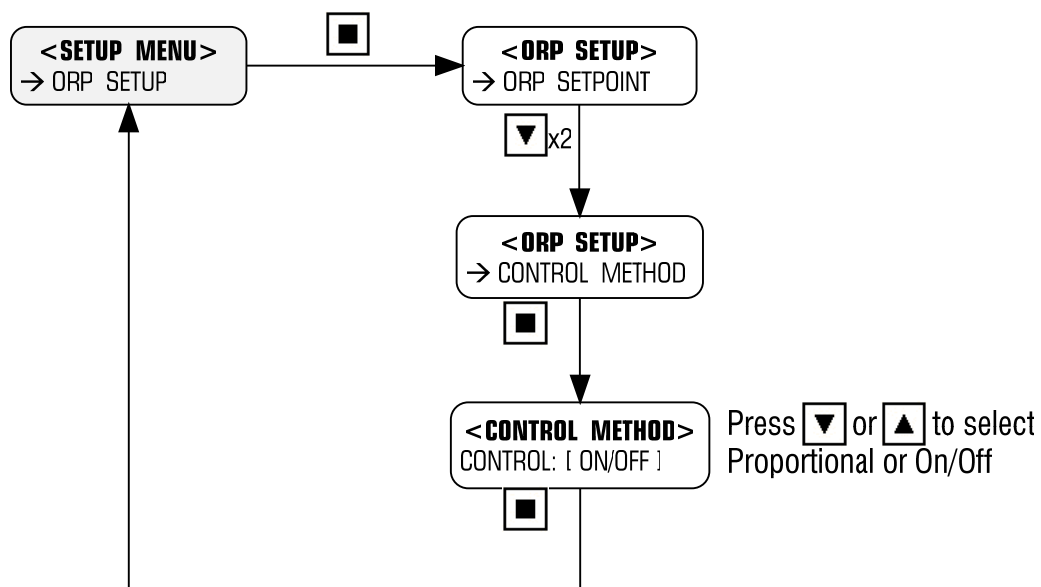

Step 2:

Program the Hysteresis

(**Note:** This menu item will only appear if ON/OFF control is selected first)

Main Menu > **SETUP MENU** > **ORP SETUP** > **HYSTERESIS**

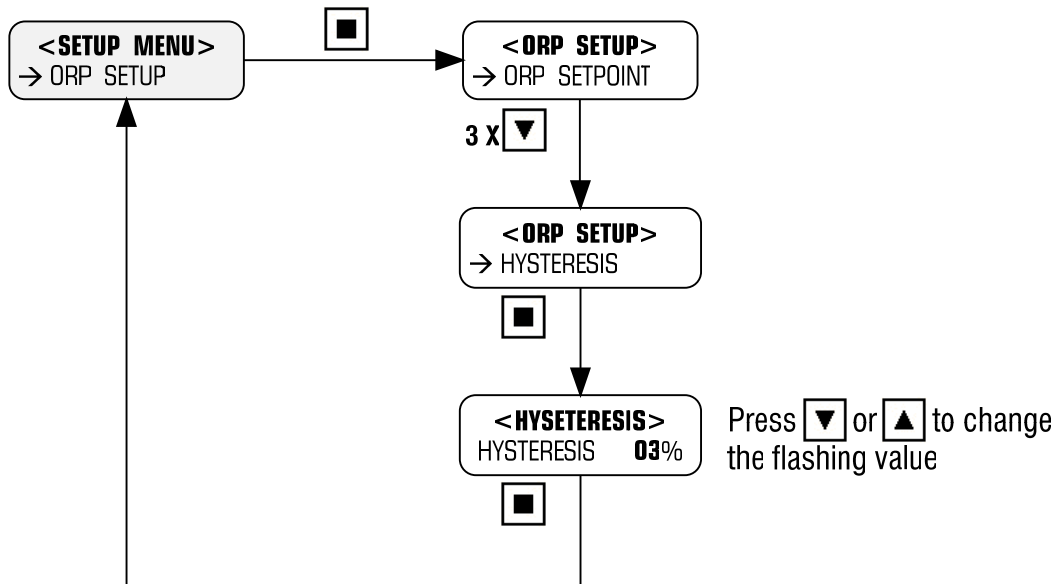

Step 3:

Program the Dose Cycle

Main Menu > **SETUP MENU** > **ORP SETUP** > **DOSE CYCLE**

When the controller calls for dosing, the pump can be programmed to dose continuously or on a cycle until it reaches the ORP Setpoint. A cycle is recommended to reduce overshoot, and to preserve the life of the pump.

The menu asks for a Dose Time and a Wait Time to be programmed. The Wait Time follows the Dose Time, and the cycle is repeated until the Setpoint plus/minus hysteresis is reached. The following diagram illustrates a dose cycle programmed for a 10 second dose followed by 40 second wait:

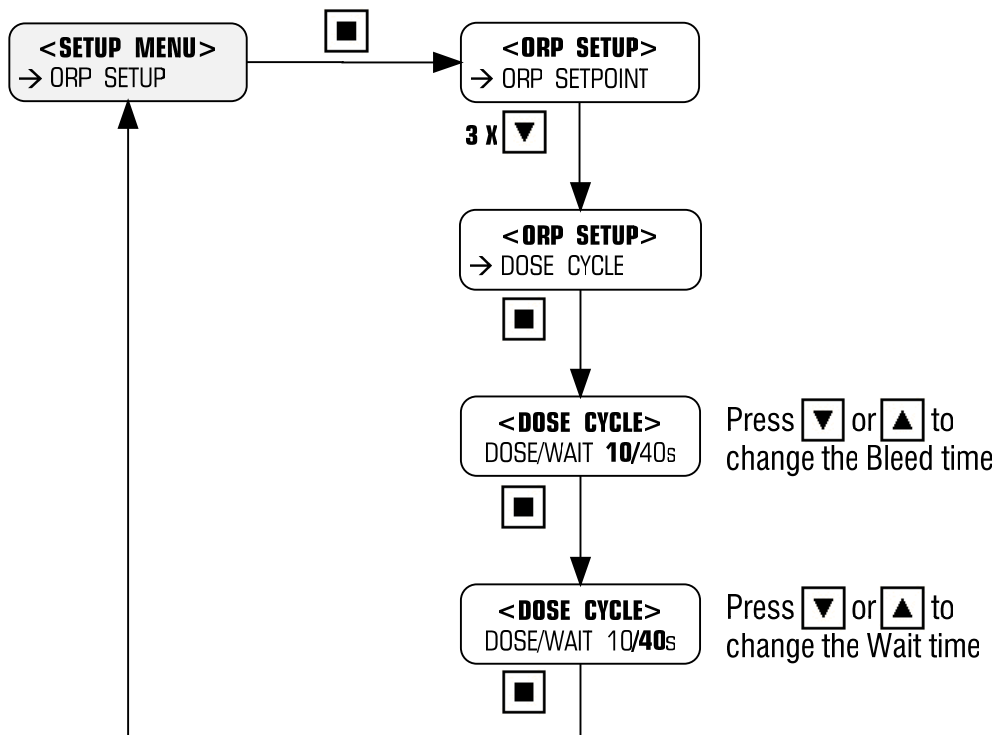

In the example above, the pump doses 10 seconds during every 50 second cycle (ie 10+40), which equates to a 20% duty cycle.

The function of the dose cycle is to assist in reducing overshoot by achieving an ORP change more slowly. In a large system, there is often a lag after dosing until the ORP sensor realises a change in ORP. The lag time estimated should be programmed as the Wait time.

Should the ORP readout drift more than 25% away from the programmed Setpoint the controller automatically doubles the Dose time and halves the Wait time to bring the ORP within 25% of the Setpoint very quickly. As soon as the ORP readout comes back to within 25% of the Setpoint, normal pump duty cycle (ie. programmed Dose/Wait times) will resume. In the example above, the Dose and Wait times will temporarily be 20 seconds each, i.e. the pump will dose for 20 seconds during every 40 second cycle, which equates to a 50% duty cycle.

If you wish to have the control output continuously active during dosing (rather than cycling ON and OFF), simply set the Dose/Wait times to 00/00s

5.7.2 PROPORTIONAL Control

With proportional control, the controller will always attempt to keep the ORP as close as possible to the Setpoint. For proportional control to work, the controller requires the Setpoint as well as 2 other parameters to be programmed:

- The Proportional Band, and
- The Control Cycle

The **Proportional Band**, set as a percentage of the Setpoint, is the band in which proportional control takes place. For example if the Setpoint = 500 mV, and the Proportional band is 10%, then proportional control takes place between 500 mV and 550 mV (dosing reductant) or between 500 mV and 450 mV (dosing oxidant).

Once the Setpoint is reached, the control output is OFF continuously. Outside of the proportional band on the opposite end, the control output is ON continuously.

Proportional control, which takes place within the proportional band is explained as follows:

Assuming a pump is connected to the control output, the controller will modulate the power supply to the dosing pump proportionally. This modulation is an ON/OFF cycle (called the Control Cycle) where the ON/OFF ratio reduces the closer the ORP is to the Setpoint (i.e. The ON time is much shorter than the OFF time). Conversely, if the ORP starts drifting away from the Setpoint (but still within the proportional band), the ON time starts getting longer with respect to the OFF time.

The **Control Cycle** is the other parameter to be programmed. Whilst dosing, if the ORP reading on the LCD changes very quickly, the Control Cycle will need to be as short as possible, eg 10 seconds. This will reduce overshoot, as the controller will be able to adjust its dose rate very quickly in responding to a rapidly changing ORP.

Conversely, in a large system with a large volume of water, and a slow recirculation rate, the ORP reading may take a long time to change after dosing occurs. In this case, it is better to have a longer Control Cycle, eg 100 seconds, to allow for the ORP reading to change, before further dosing takes place.

If unsure, set the control cycle to your best estimate of the time it takes for the water where the chemical is injected into, to get back to the ORP sensor.

Step 1:

Select the Proportional Control Method

Main Menu > **SETUP MENU** > **ORP SETUP** > **CONTROL METHOD**

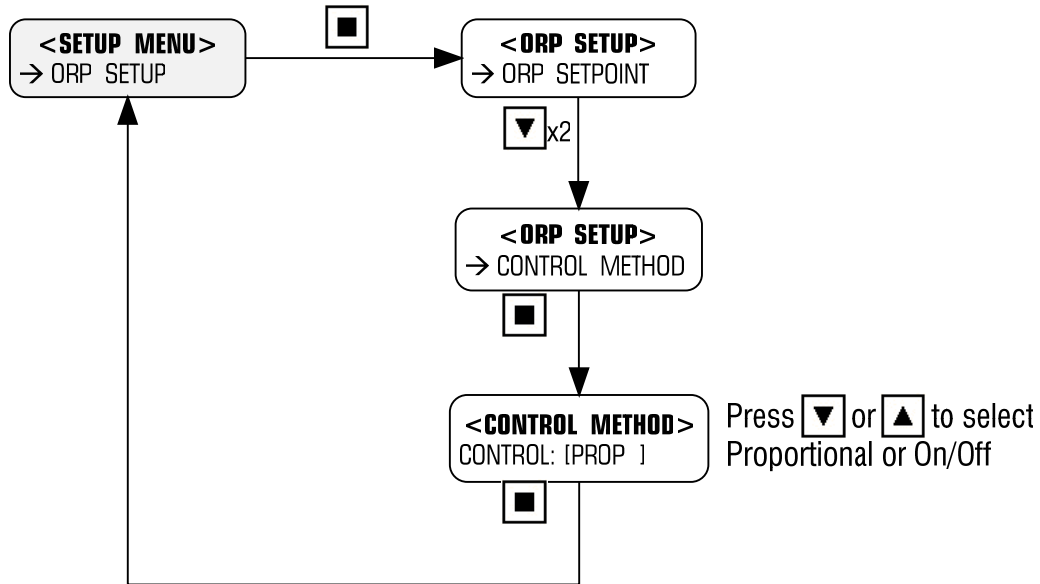

Step 2:

Program the Proportional Band

(**Note:** This menu will only appear if PROP. control is selected first)

Main Menu > **SETUP MENU** > **ORP SETUP** > **PROPORTIONAL BAND**

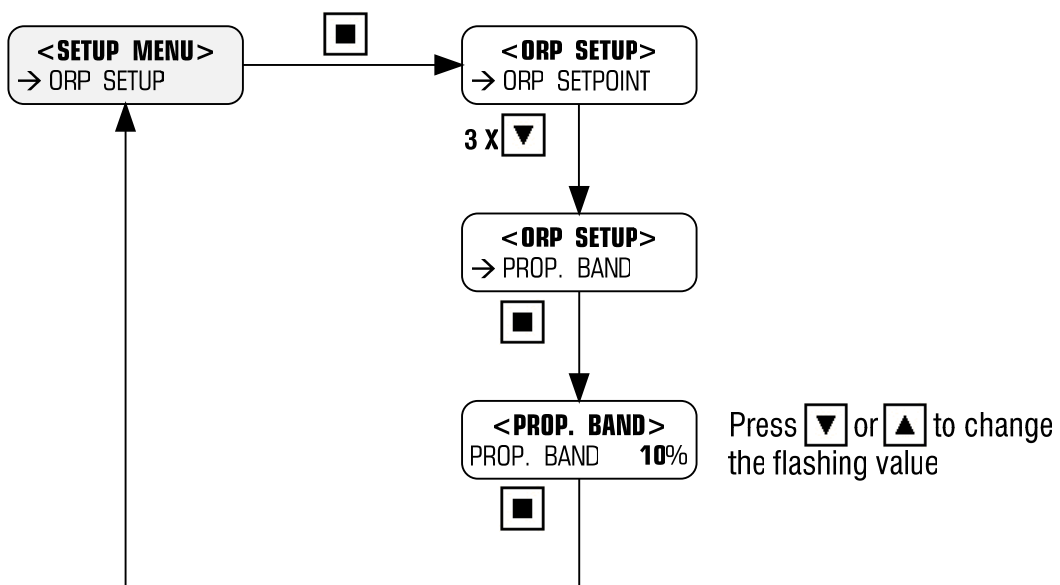

Step 3:

Program the Control Cycle

Main Menu > **SETUP MENU** > **ORP SETUP** > **CONTROL CYCLE**

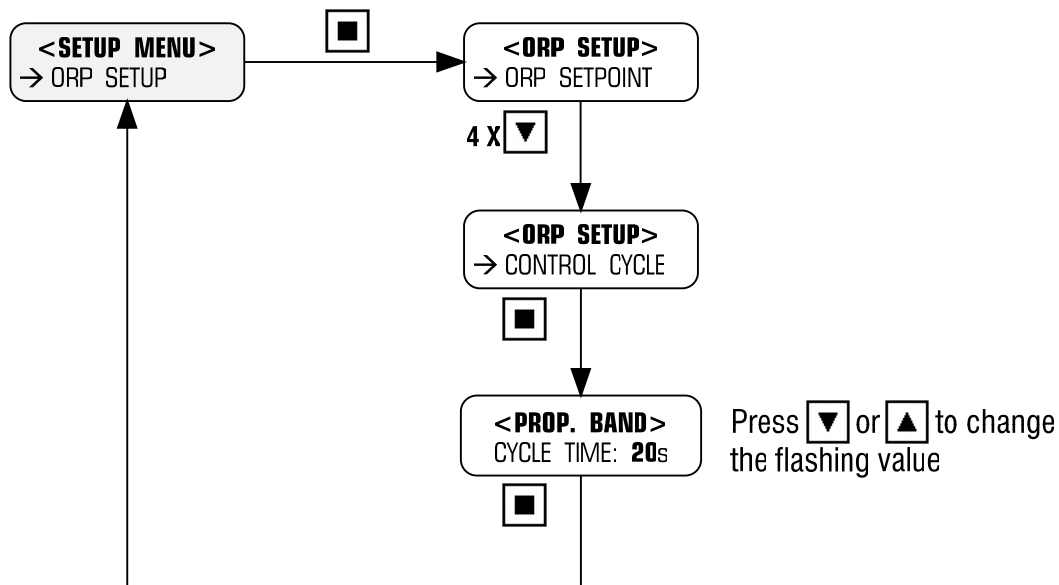

Example of Operation:

- Operation = Dosing Oxidant
- Setpoint = 500 mV
- Proportional Band = 10% (i.e. 450 mV to 500 mV)
- Control Cycle = 20 seconds

Above 500 mV, the pump is OFF continuously.

As the ORP drops below 500 mV, the pump starts dosing for 1 second every 20 seconds (ie. ON/OFF cycle = 1s/19s). If the ORP drops to 480 mV, the pump will dose for 8 seconds every 20 seconds (ie. ON/OFF cycle = 8s/12s). As the dose rate increases, ie ON/OFF ratio increases, the ORP mV reading should start rising again with the aim of getting as close to the Setpoint as possible.

On start-up, the pump will dose continuously until the ORP reading rises to 450mV. Above 450mV the pump will start cycling ON and OFF, with a very short OFF time initially. As the ORP continues to rise above 450mV, the pump will slow down (ie. OFF time will increase). If the mV reading reaches the setpoint of 500 mV, the pump will stop altogether.

5.8 Alarm Parameters

Main Menu > SETUP MENU > ALARM SETTINGS

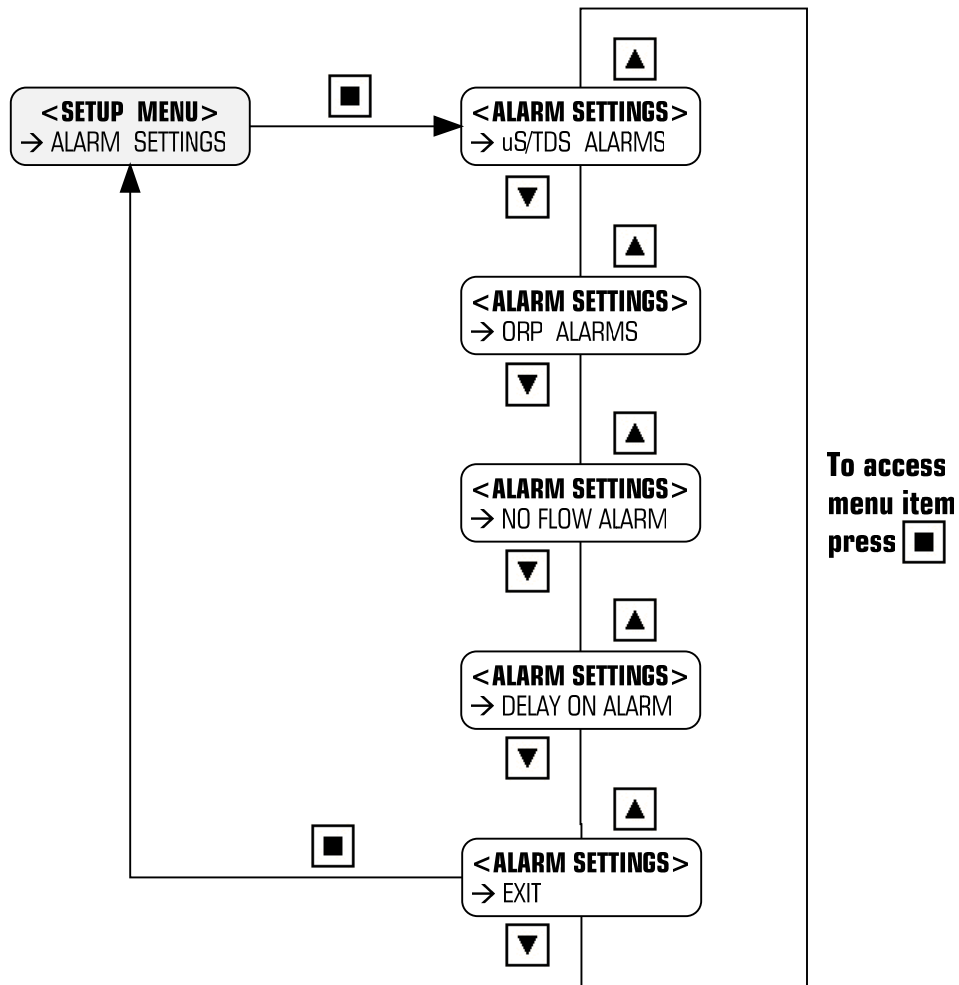

The controller has 5 programmable alarm functions as outlined above. If any of the alarms are activated and confirmed, the common alarm contact switches, the red Alarm LED illuminates, and the Alarm message is displayed on the LCD.

5.8.1 μ S/TDS Alarms

Similar to the main menu, the DIGICHEM-ORP-XP2 has a separate circular sub menu structure for the Conductivity alarm settings as is shown below.

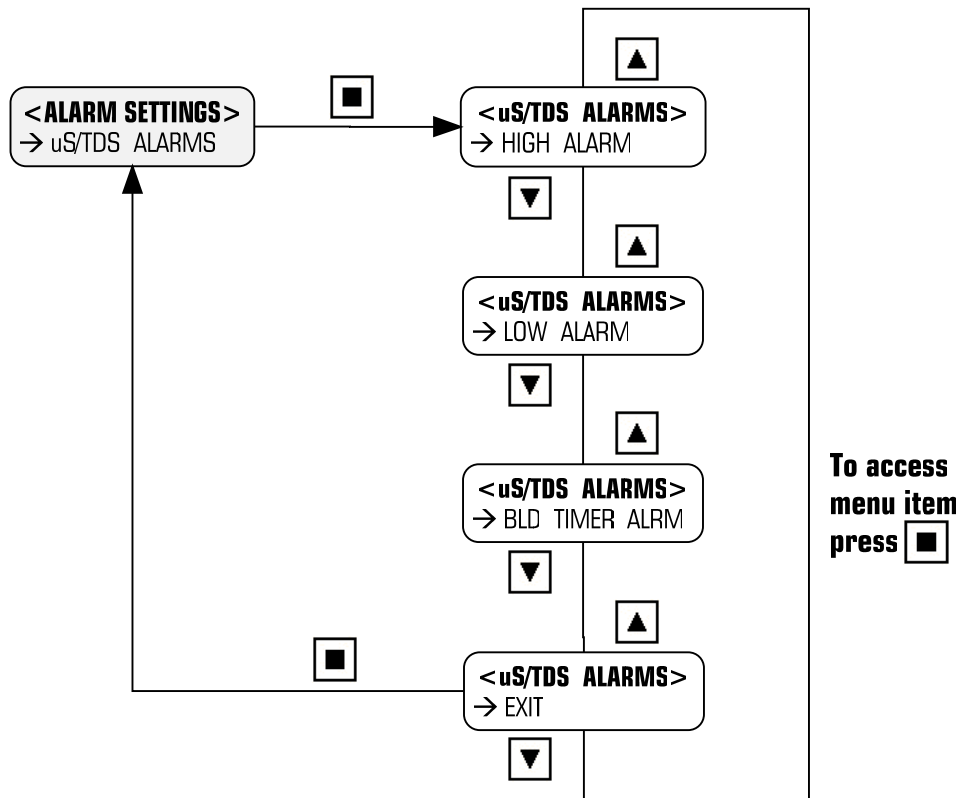

5.8.1.1 High Conductivity Alarm

The High Conductivity Alarm is activated if the Conductivity rises above the programmed setting, and automatically resets if the Conductivity drops below the programmed setting again.

Main Menu > **SETUP MENU** > **ALARM SETTINGS** > **μ S/TDS ALARMS** > **HIGH ALARM**

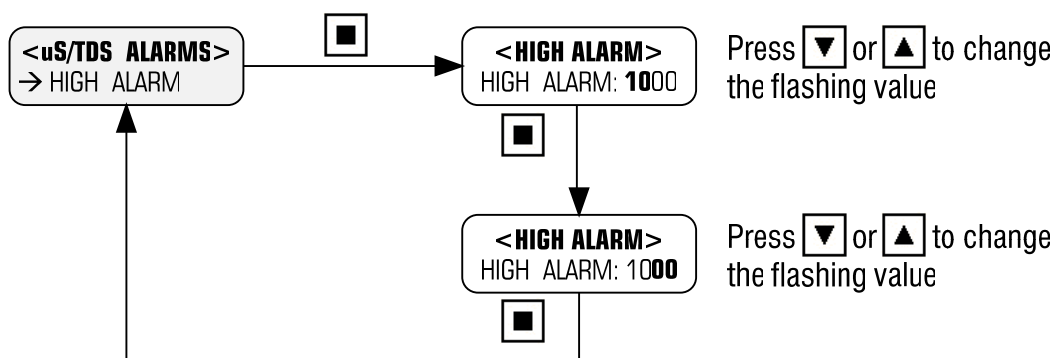

Note: A setting of 0000 means the High Alarm is disabled.

5.8.1.2 Low Conductivity Alarm

The Low Conductivity Alarm is activated if the Conductivity drops below the programmed setting, and automatically resets if the Conductivity rises above the programmed setting again.

Main Menu > **SETUP MENU** > **ALARM SETTINGS** > **μS/TDS ALARMS** > **LOW ALARM**

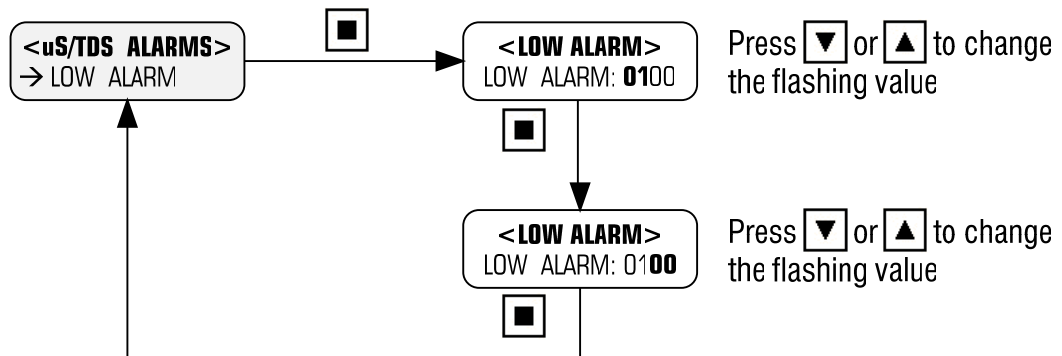

Note: A setting of 0000 means the Low Alarm is disabled.

5.8.1.3 Bleed Timer Alarm

Main Menu > **SETUP MENU** > **ALARM SETTINGS** > **μS/TDS ALARMS** > **BLD TIMER ALARM**

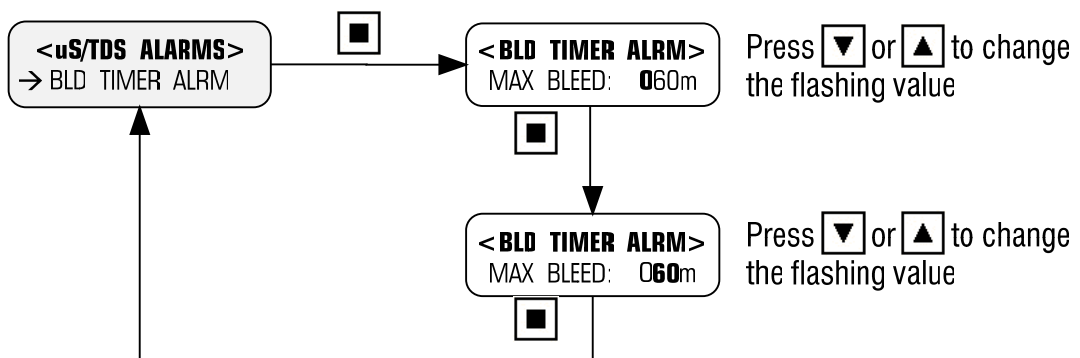

The Bld (Bleed) Timer Alarm is the maximum acceptable bleed time for the system to reach the Setpoint. This alarm is designed to protect the system from excessive bleeding in the event of a false reading from a faulty Conductivity probe, or if the controller itself is faulty.

To leave the alarm in its disabled state, the programmed setting is 000m. If the system Conductivity reaches the Setpoint within the programmed time, the timer resets. However, if the timer times out before the Conductivity reaches the Setpoint, the bleed solenoid switches off and remains disabled until the unit is manually reset by holding down the Alarm Reset pushbutton.

NOTE: A setting of 000m means the Timer Alarm is disabled.

5.8.2 ORP Alarms

Similar to the main menu and uS/TDS Alarms sub menu, the DIGICHEM-ORP-XP2 has a separate circular sub menu structure for the ORP alarm settings as is shown below.

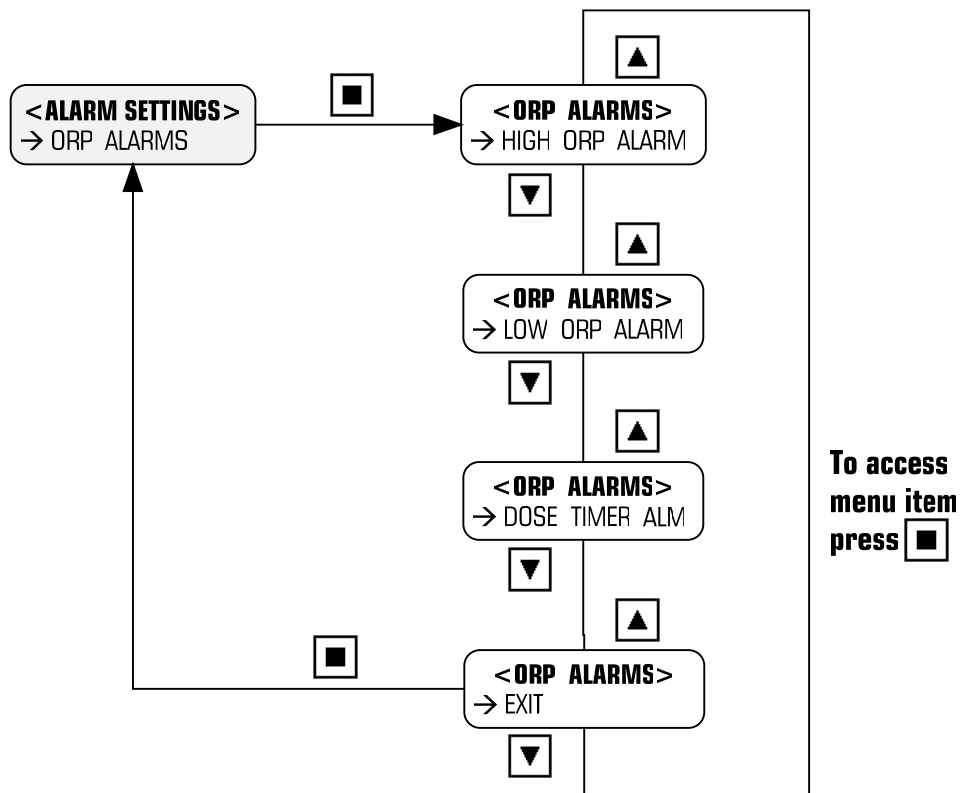

5.8.2.1 High ORP Alarm

The High ORP Alarm is activated if the ORP rises above the programmed setting.

Main Menu > **SETUP MENU** > **ALARM SETTINGS** > **ORP ALARMS** > **HIGH ORP ALARM**

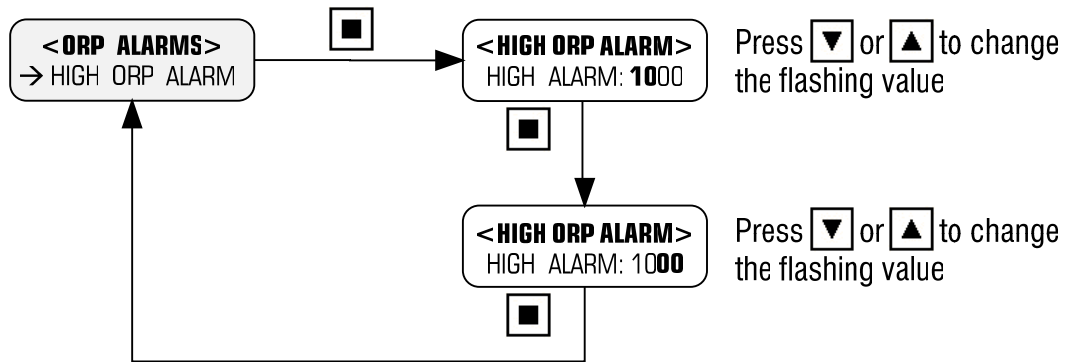

NOTE: A setting of 0000 means the High Alarm is disabled.

5.8.2.2 Low ORP Alarm

The Low ORP Alarm is activated if the ORP drops below the programmed setting.

Main Menu > **SETUP MENU** > **ALARM SETTINGS** > **ORP ALARMS** > **LOW ORP ALARM**

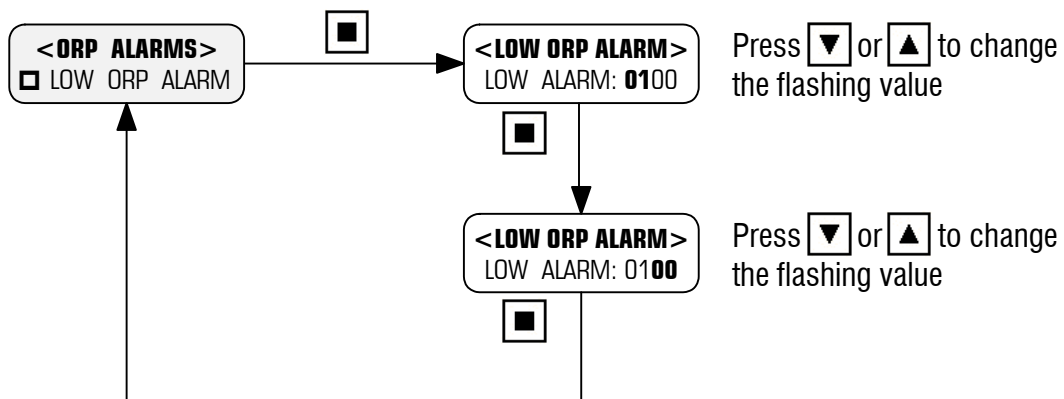

NOTE: A setting of 0000 means the Low Alarm is disabled.

5.8.2.3 Dose Timer Alarm

The Dose Timer Alarm is the maximum acceptable dose time to reach the Setpoint. This alarm is designed to protect the system from overdosing in the event of a false reading from a faulty ORP sensor, a dry sensor, a disconnected sensor, or if the controller itself is faulty.

If programmed to dose oxidant (/reductant), the ORP reading on the controller could be low (/high) when in fact the actual ORP of the system is much higher (/lower), resulting in dosing when there should be no dosing. The Timer Alarm stops this false dosing condition as soon as the Timer Alarm times out.

To leave the alarm in its disabled state, the programmed setting is 000m.

If the system ORP reaches the Setpoint within the programmed time, the timer resets. However, if the timer times out before the ORP reaches the Setpoint, the pump switches off and remains disabled until the unit is manually reset by holding down the Reset pushbutton.

Main Menu > **SETUP MENU** > **ALARM SETTINGS** > **ORP ALARMS** > **DOSE TIMER ALARM**

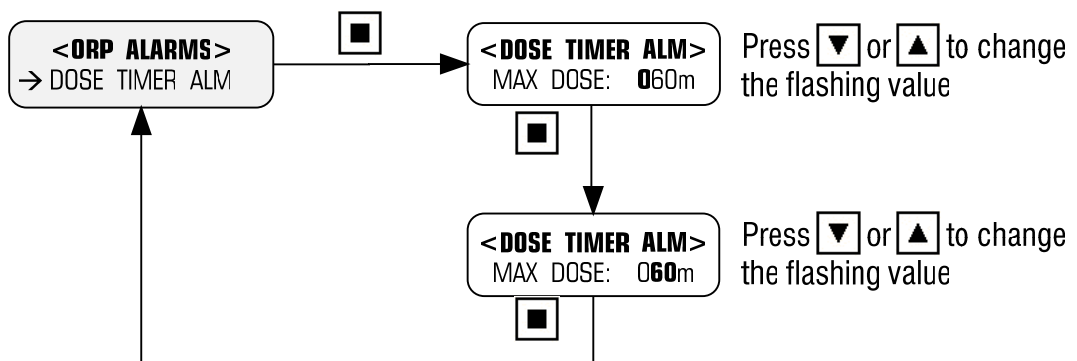

NOTE: A setting of 000m means the Timer Alarm is disabled.

5.8.3 No Flow Alarm

Main Menu > SETUP MENU > ALARM SETTINGS > NO FLOW ALARM

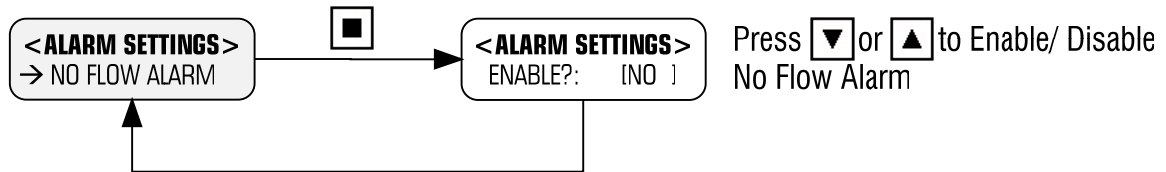

If the No Flow Alarm is enabled, the Alarm will activate when there is no flow detected by the flow switch. If the No Flow Alarm is left disabled, then the Alarm is unaffected by a no-flow condition.

5.8.4 Delay On Alarm

Main Menu > SETUP MENU > ALARM SETTINGS > DELAY ON ALARM

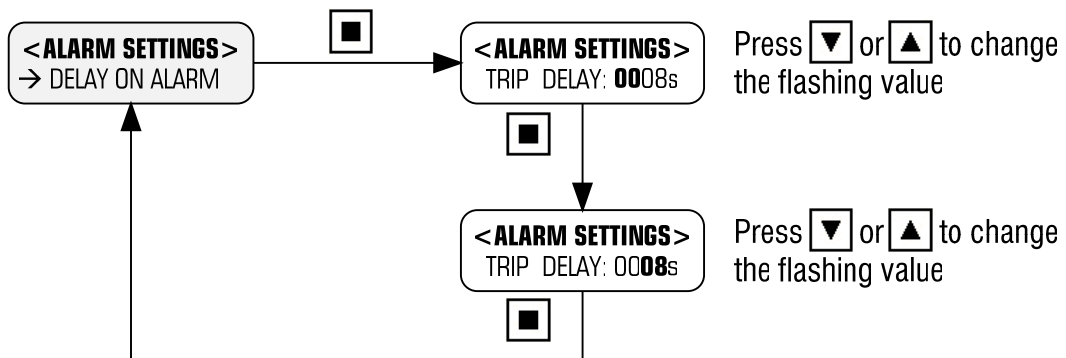

When an alarm condition is detected, eg High Conductivity or ORP Alarm, the relay only trips immediately if the Trip Delay is set to 0 seconds. However, if alarms do not become immediately critical, it is better to program a delay on the alarm to prevent "nuisance trips".

If a Trip Delay, eg. 120s, is programmed, the alarm relay will only trip if the High Conductivity condition exists continuously for 120 seconds. However, if the Conductivity drops to below the High Conductivity Alarm level before the 120 seconds times out, the Alarm condition will reset.

Whilst the Trip Delay is timing, the red Alarm LED will flash. If the alarm condition still exists after the time delay, the LED will illuminate continuously until the alarm cancels, at which point, the LED goes off.

5.9 Inhibitor Setup

Main Menu > SETUP MENU > GENERAL SETUP > INHIBITOR SETUP

There are 4 Possible Inhibitor Feed Pump Modes to select from:

- Continuous on Bleed
- % of Time on Bleed
- % of Time on Flow (24 hrs/day) – [**Note:** Optional Flow Switch required]
- Water Meter Pulse

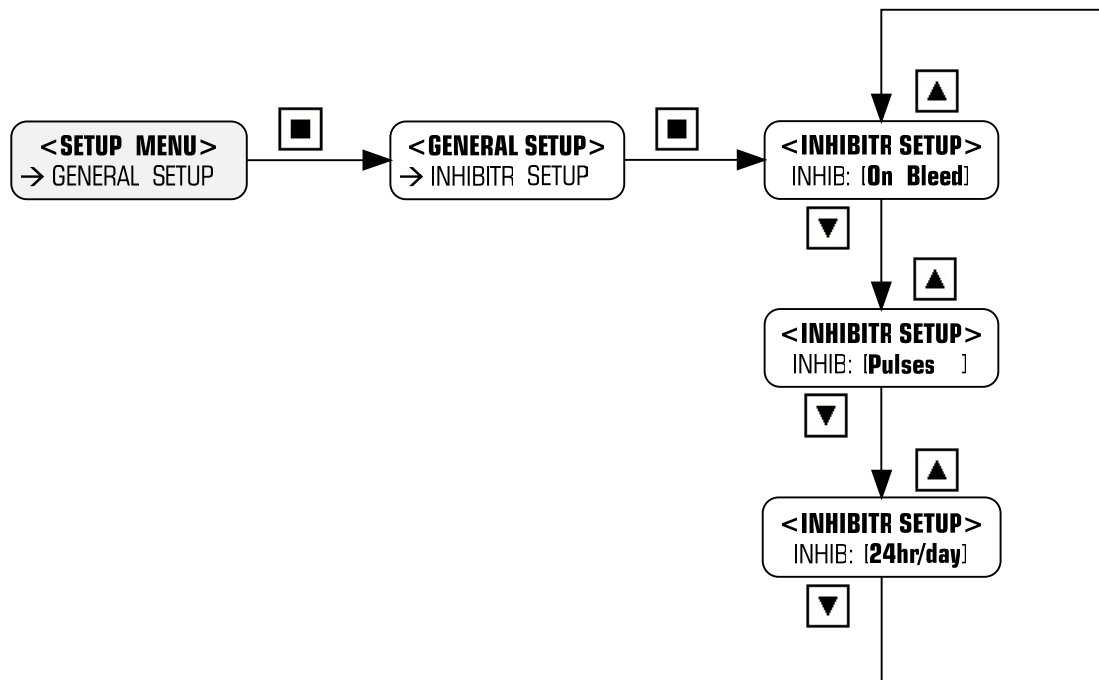

Continuous on bleed:

Pump doses continuously when measured Conductivity > Setpoint, regardless of any bleed cycle programmed.

% of Time on Bleed:

Pump doses on a duty cycle when measured Conductivity > Setpoint, independent from any bleed cycle programmed. Duty cycle is repeating ON and OFF times, eg ON=30sec, followed by OFF=30sec & repeating (ie. 50% duty cycle).

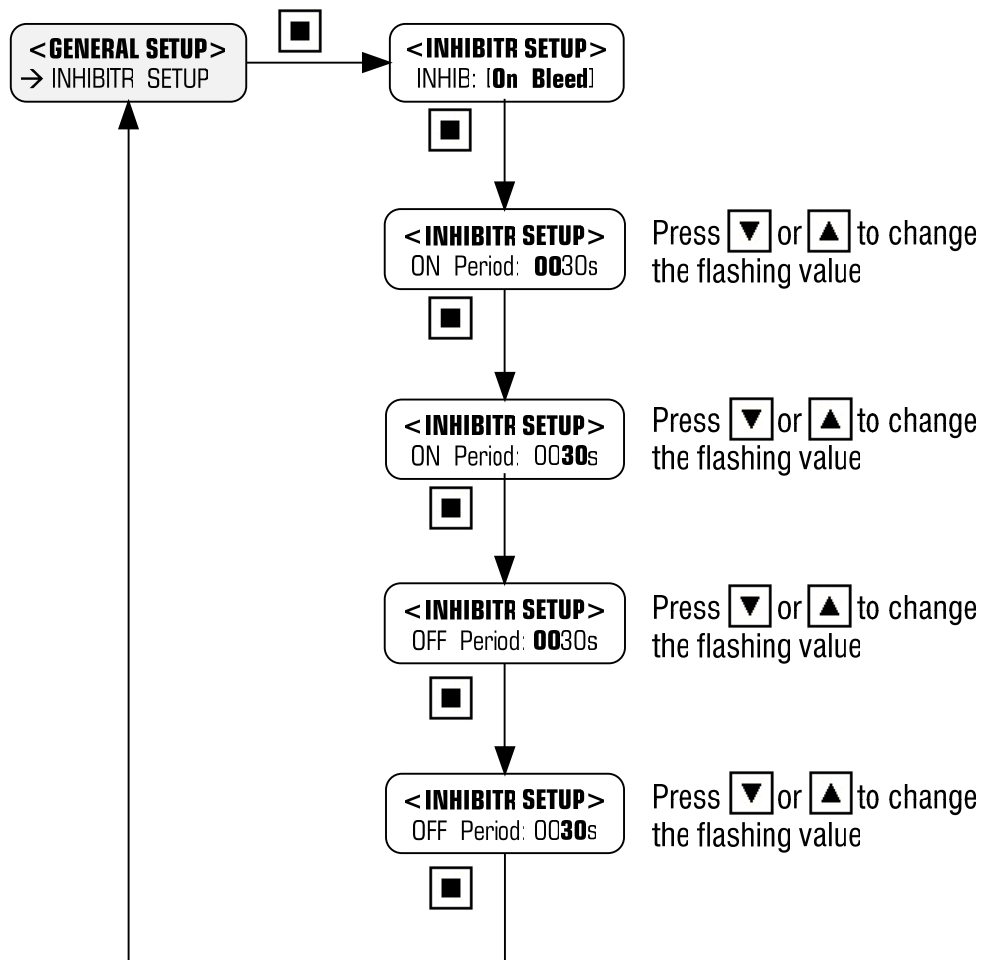

% of Time on Flow (24 hours/day):

Pump doses on a continuous duty cycle. Duty cycle is repeating ON and OFF times, eg ON=20sec, followed by OFF=60sec & repeating (ie. 25% duty cycle). If there is not continuous flow through the manifold at all times, flow switch option AF04 should be fitted.

Main Menu > SETUP MENU > GENERAL SETUP > INHIBITOR SETUP

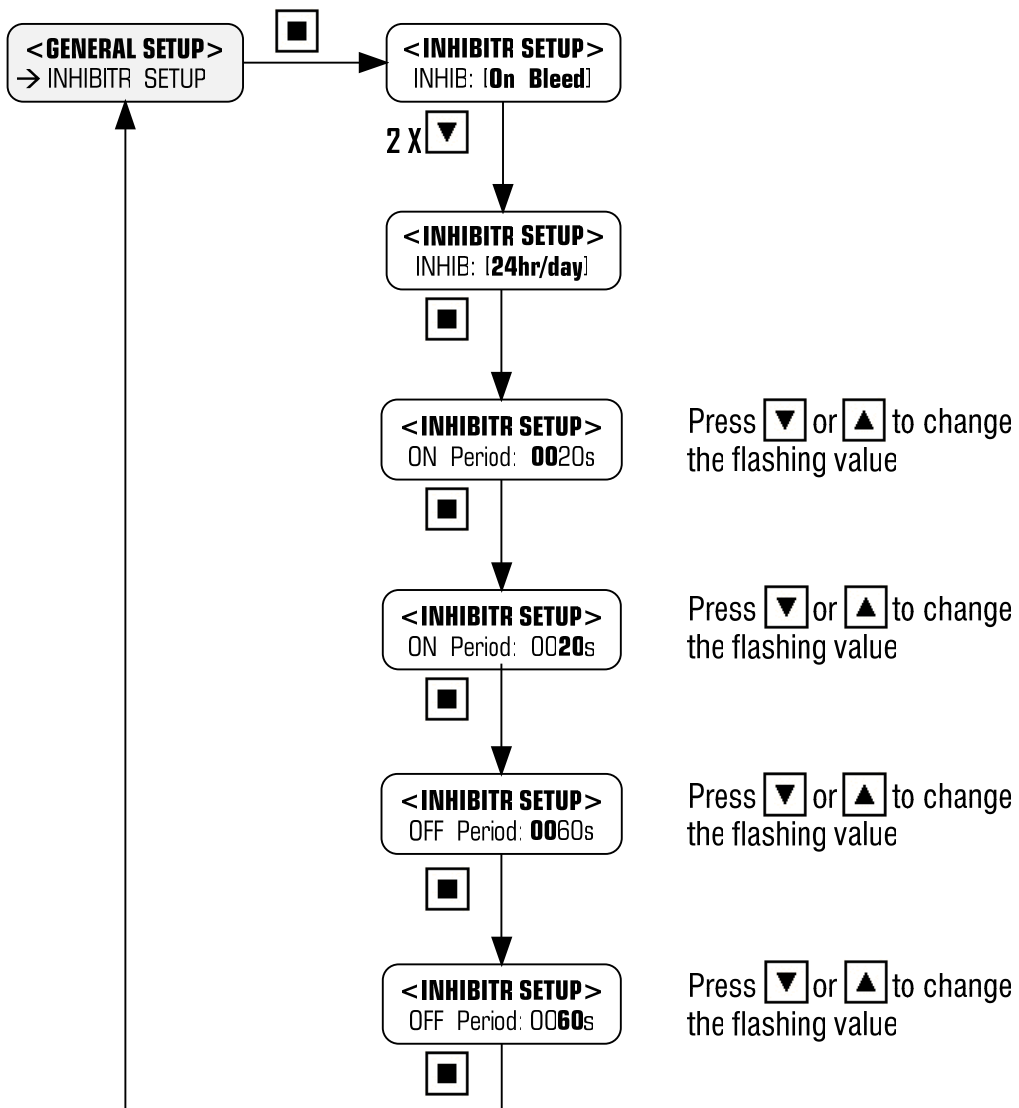

For any of the % of Time modes above, you can use the following table as a guide to set your Inhibitor pump duty cycle:

Dosing Pump Turn-down required	ON Period	OFF Period
10% of maximum dose rate	0010s	0090s
20% of maximum dose rate	0020s	0080s
30% of maximum dose rate	0030s	0070s
40% of maximum dose rate	0040s	0060s
50% of maximum dose rate	0050s	0050s
60% of maximum dose rate	0060s	0040s
70% of maximum dose rate	0070s	0030s
80% of maximum dose rate	0080s	0020s
90% of maximum dose rate	0090s	0010s
100% of maximum dose rate	0000s	0000s

Water Meter Pulse:

Pump doses proportional to pulses received from a water meter fitted in the make-up line. The DIGICHEM-XP2 activates the pump for a set time once a pre-determined number of pulses is counted, explained further in the following example:

Water meter pulse rate = 1 pulse / litre
 Desired concentration = 100 p.p.m.

[100 p.p.m. = 10ml chemical / 100 litres flow = 10ml chemical / 100 pulses]

Hence, we require the pump to dose 10ml every 100 pulses counted.

How long does the pump need to dose to deliver 10ml?

Pump dose rate = 1300ml/hr = **0.36ml/sec**

Dose time = 10ml / 0.36ml/sec = **27.8 seconds** (i.e. approx. 30 sec)

Set *PULSE COUNT* = 100
 Set *DOSE PERIOD* = 30 seconds

In the example below, the pump doses for 30 seconds (i.e. programmed dose time) every 100 litres of make-up water (i.e. programmed pulse count of 100).

NOTE: An asterisk '*' flashes on the normal screen every time the controller receives a pulse from the optional water meter.

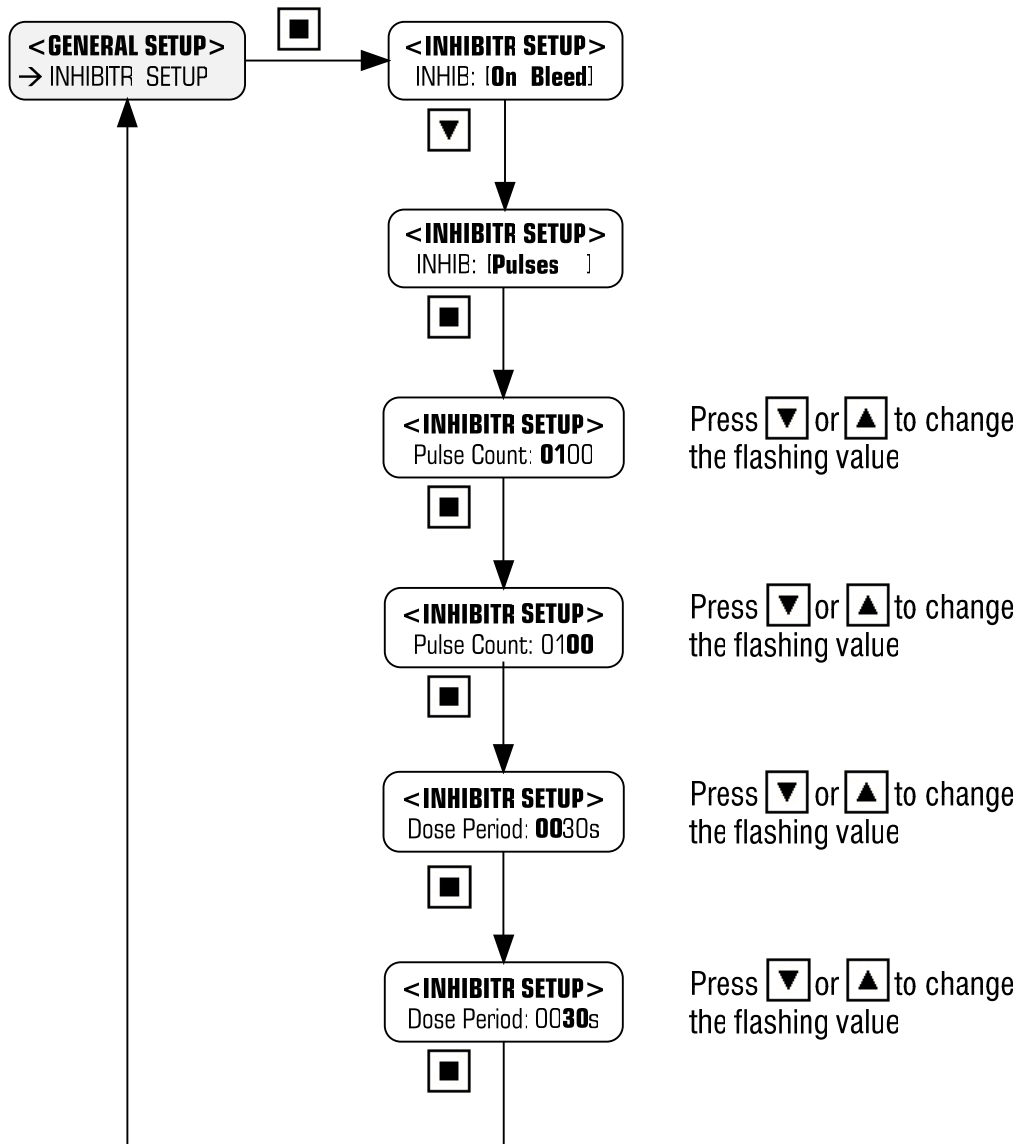

5.10 Biocide Setup

Biocide is dosed according to **28 day timer programs** set up by the user. There are 10 independent programs which can be programmed to operate daily, once per week, or on any number of days per week, fortnightly or once a month. A typical biocide program, which will operate at the same time on the specified days of the week, consists of 3 consecutive time durations:

1. Pre-bleed
2. Biocide Dosing
3. Bleed Lock-out

1. Pre-bleed

This reduces the system conductivity to a lower temporary setpoint (eg. 85% of setpoint) prior to biocide dosing in order to allow for a longer Bleed Lock-out duration without the risk of entering scaling conditions. Pre-bleed duration is programmable from 1 minute up to 23 hours. (Note: The Pre-Bleed Setpoint of 85%, ie. Setpoint -15% is fully programmable, and is explained further in section 5.8).

2. Biocide dosing

The biocide pump (Pump A or Pump B) doses chemical, typically into a manifold. Dose duration is programmable from 1 minute up to 23 hours and commences immediately after Pre-Bleed. Bleed-off is disabled (ie. locked out) during dosing provided the Bleed Lock-out setpoint is not exceeded.

3. Bleed Lock-out

After biocide dosing, bleed-off continues to be disabled for the lock-out duration, programmable from 1 minute up to 23 hours, provided the Bleed Lock-out setpoint is not exceeded. (Note: The default Bleed Lock-out Setpoint of Setpoint +20% is fully programmable, and is explained further in section 5.12).

By preventing bleed-off during and after biocide dosing, the system is ensured of receiving maximum benefit from the dosed biocide, as no biocide will be lost during this time via bleed-off. Furthermore, because the conductivity is reduced during Pre-Bleed, the system has a longer retention period. As a result, a highly effective "kill" is achieved without resulting in high scaling conditions.

Each of the 10 Biocide Dosing programs can be set up to operate Biocide pump A or Biocide pump B/ORP. In other words, the programs can be allocated in any combination to either of the two biocide outputs, A and B/ORP.

For instance, if pump A is set up in 6 programs, pump B/ORP can only have up to 4 programs controlling it. Not all of the programs need to be allocated. If only two of the programs are required, then the other 8 will remain disabled. Pump A and Pump B/ORP work totally independently and each program has its own START TIME, followed by its own consecutive PRE-BLEED, BIOCIDES DOSING and BLEED LOCK-OUT durations. **However, biocide programs should not overlap.**

NOTE: When a timer program is initially entered, the controller will control as per normal, until the end of the timer program. At the end of the timer program, the outputs will then go into an "Idle" state. The outputs will be in an "Idle" state until the Timer program is activated again.

Main Menu > SETUP MENU > GENERAL SETUP > BIOCIDES SETUP

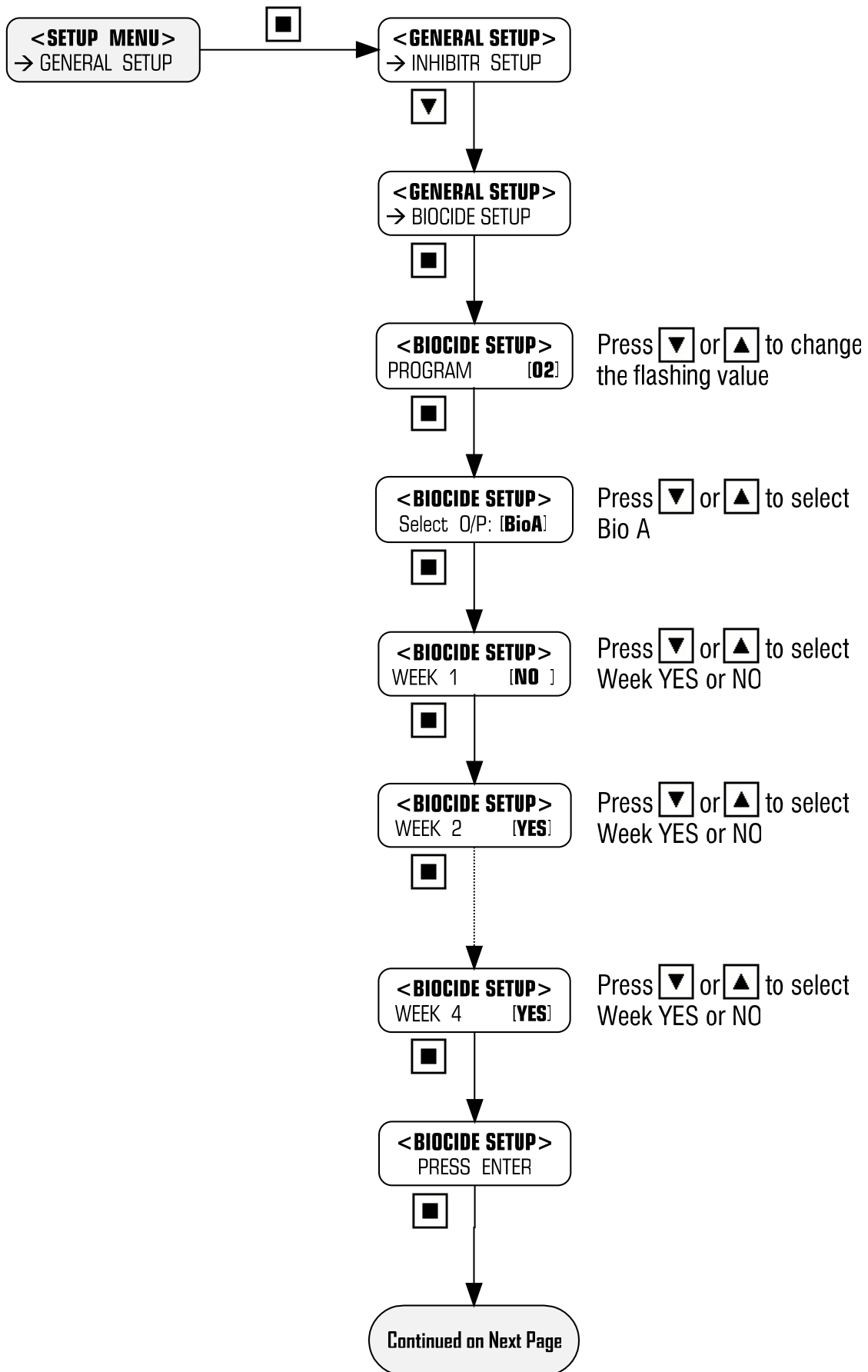

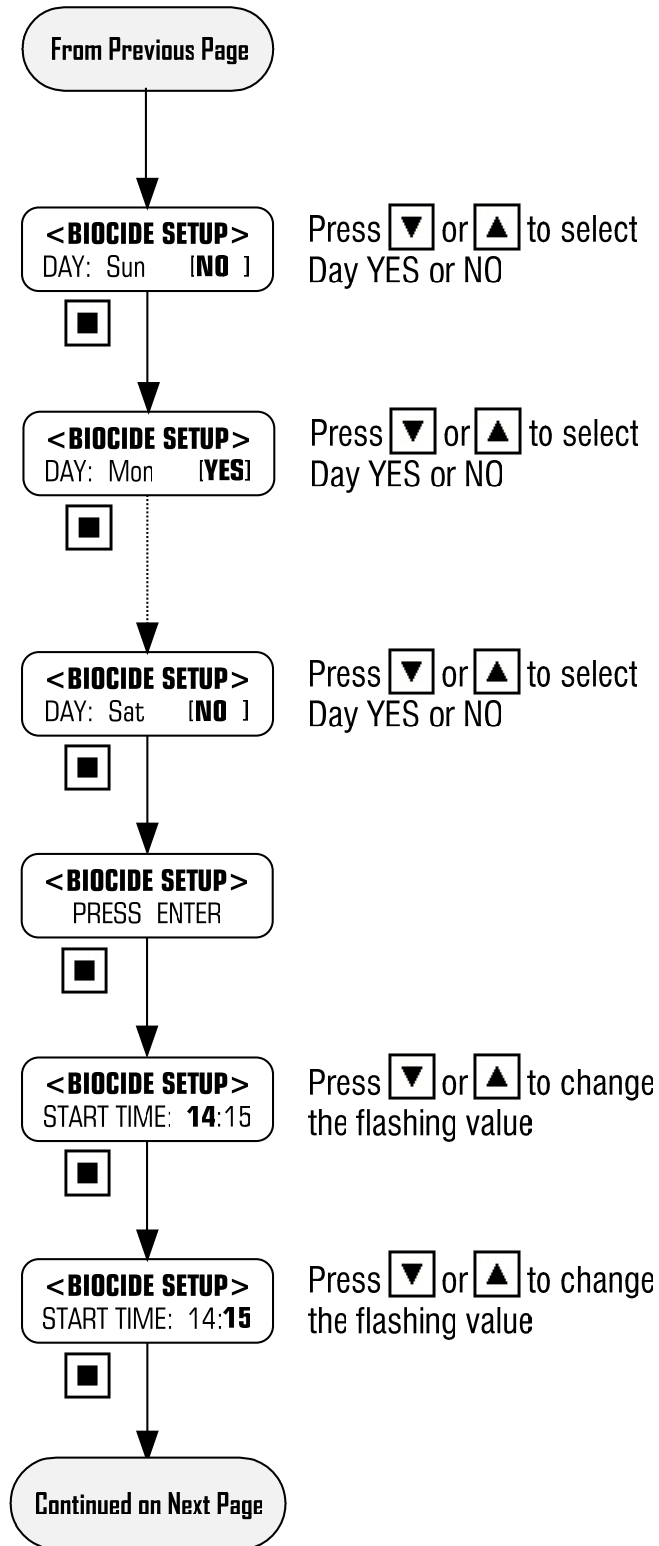

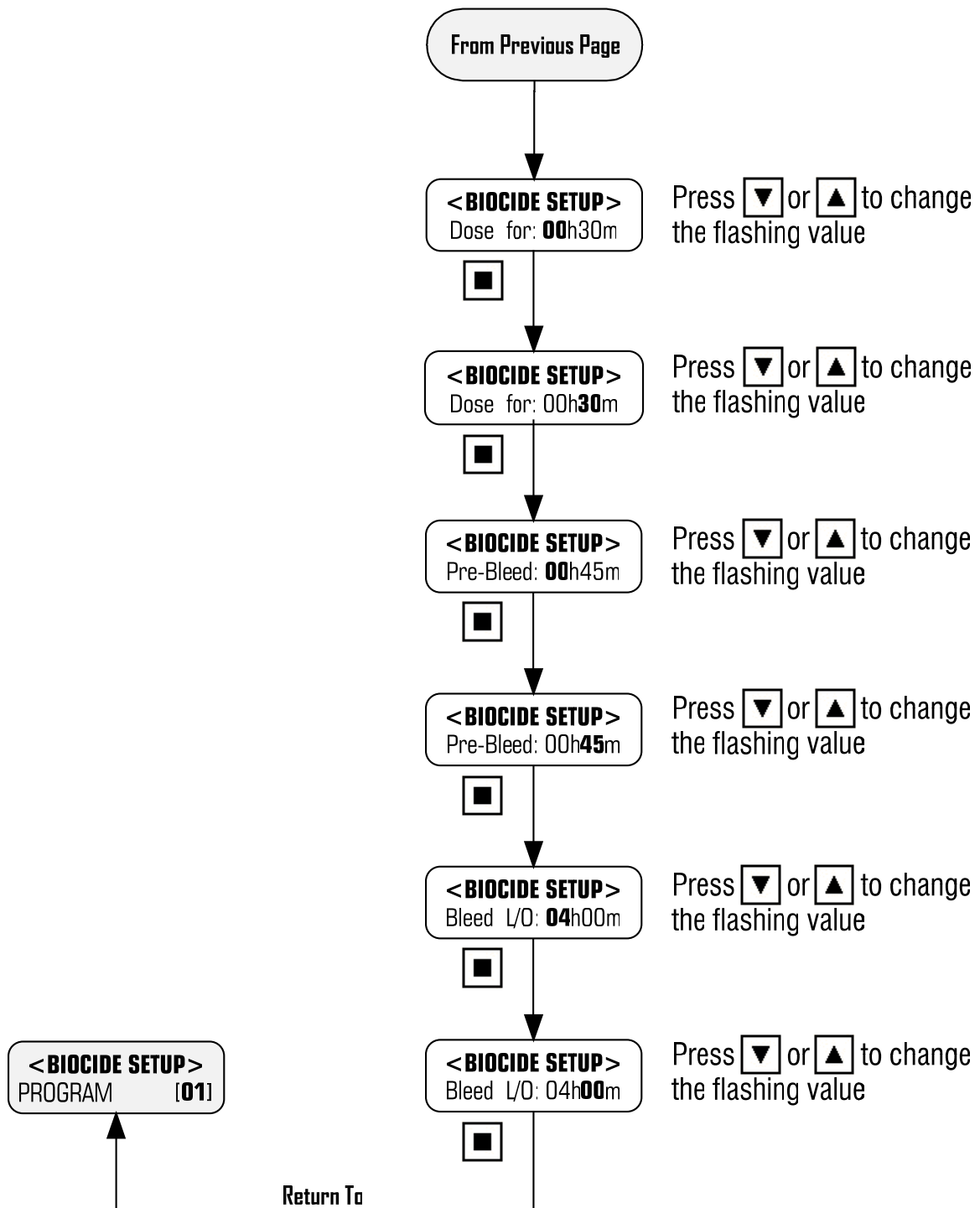

Example: Setting a Biocide Dosing Program (i.e. 2) to take place in Week 2 and Week 4, on a Monday beginning at 14:15. Biocide will be dosed for 30 minutes after a pre-bleed time of 45 minutes, after which bleed lockout will occur for 4 hours.

However, this menu will change, if ORP is enabled.

The example below shows the menu structure using the previous example, where instead of Pump A, the ORP Output will be activated:

NOTE: For this selection, Pre-Bleed and Bleed Lockout will not appear in the menu, or the Main screen when the controller is inside or outside of an active period.

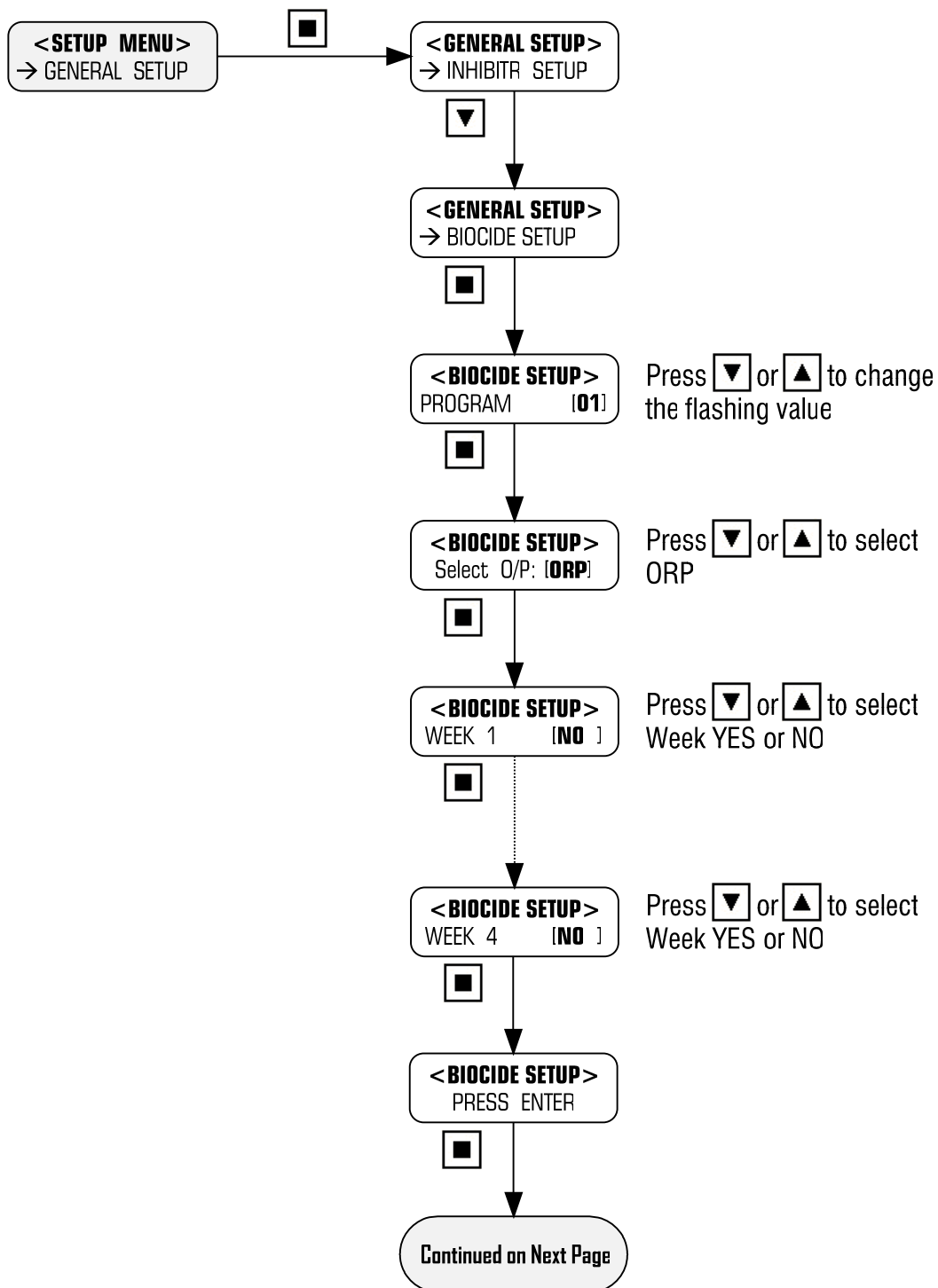

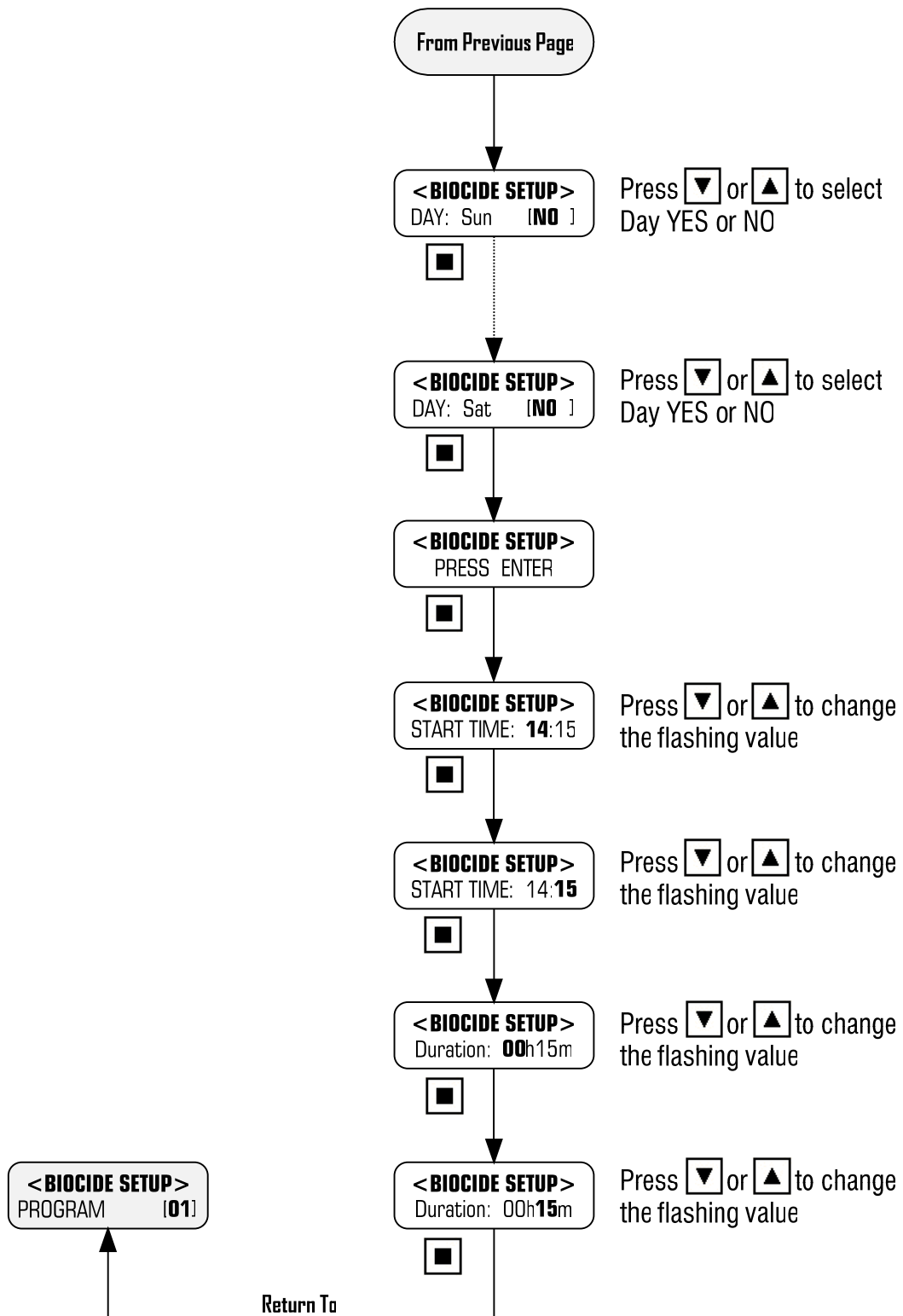

5.11 Pre-Bleed Setpoint

Main Menu > SETUP MENU > GENERAL SETUP > PRE-BLD SETPOINT

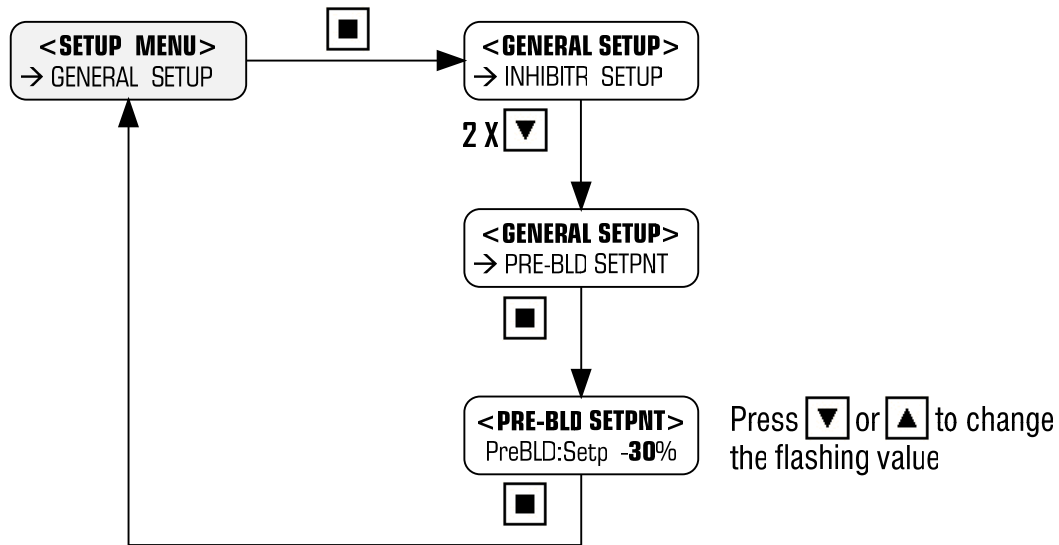

In the example above, the Pre-Bleed setpoint is set as the Normal Conductivity Setpoint less 10%. Hence, during the Pre-bleed time (ie. Immediately before biocide dosing), the normal conductivity setpoint is reduced by 10%, and the controller will try to maintain this reduced setpoint until biocide dosing commences. The objective of pre-bleed is to allow for a longer Bleed Lock-out duration without the risk of entering scaling conditions.

5.12 Bleed Lock-out Setpoint

Main Menu > SETUP MENU > GENERAL SETUP > LOCKOUT SETPOINT

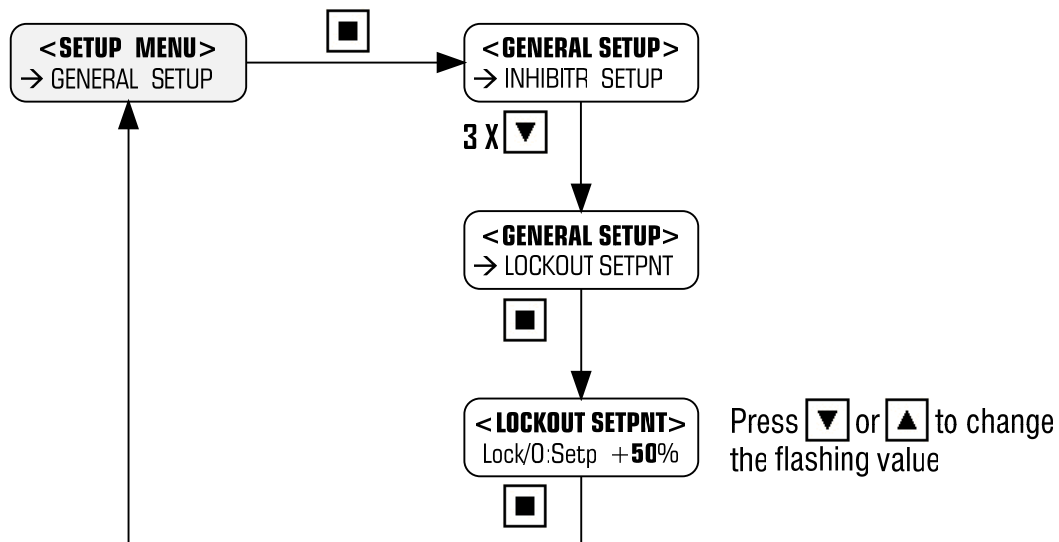

In the example above, the Lockout setpoint is set as the Normal Conductivity Setpoint plus 50%. Hence, during Biocide Dosing and during the Lockout time (ie. Immediately after biocide dosing), the normal conductivity setpoint is increased by 50%, and the controller will try to maintain this increased setpoint until the Lockout Period expires. By preventing bleed-off during and after biocide dosing, the system is ensured of receiving maximum benefit from the dosed biocide, as no biocide will be lost during this time via bleed-off. Furthermore, because the conductivity is reduced during Pre-Bleed, the system has a longer retention period. As a result, a highly effective “kill” is achieved without resulting in high scaling conditions.

5.13 Auxiliary Output On Timer

Main Menu > SETUP MENU > GENERAL SETUP > AUX O/P ON TIMER

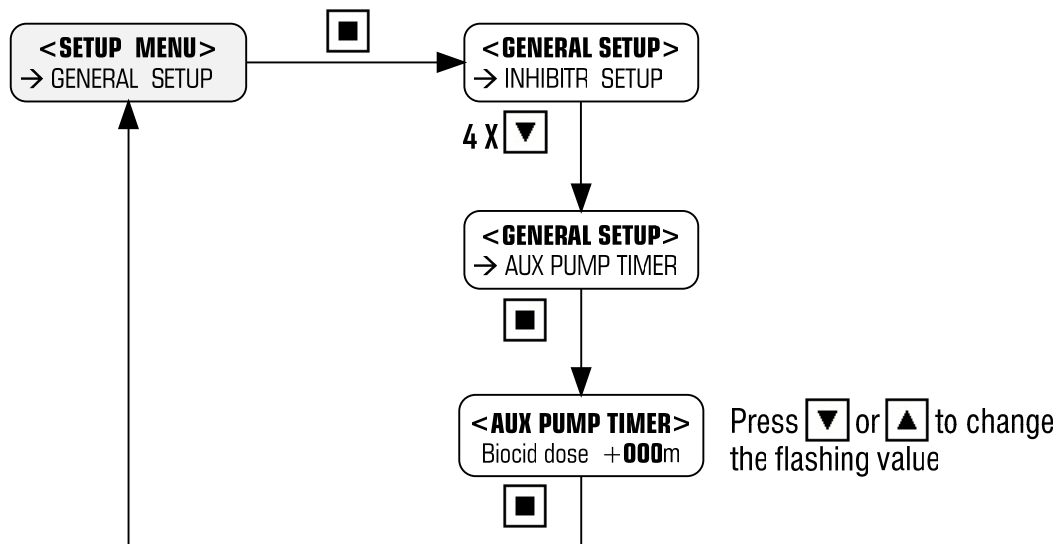

Often when biocides are dosed into the manifold of the DIGICHEM-ORP-XP2 systems, the circulating/ condenser pump of the cooling tower is not running. This can cause problems of clogging and corrosion in the manifold, as well as biocide not being dosed into the cooling tower water.

The DIGICHEM-ORP-XP2 controller has an on-board relay contact (N/O) which can be wired into the condenser pump contactor (see wiring diagram in section 2.1). The contact provided is a dry contact so can be connected in series with the condenser pump contactor circuit, or any other circuit as required. Alternatively, the relay contact can power the contactor by looping 240VAC active to the common of the relay contact and connecting the N/O contact to the coil of the contactor. Note: In this instance, the contactor must have a 240VAC coil and must be normally powered from the same 240VAC mains circuit as the DIGICHEM-ORP-XP2.

When either biocide pump starts dosing, the N/O contact closes, powering the contactor which in turn starts the condenser pump. The condenser pump will continue to run while the biocide is dosing, as well as for a period of time after biocide dosing. This ensures continuous water circulation and effective mixing of the biocide chemical.

This time that the pump runs AFTER a biocide dose, is programmed here as the Auxilliary Output ON Time.

IMPORTANT: If this feature is used, it is not recommended to switch the condenser pump on and off rapidly using the output test feature, explained in section 4.4

The following is another example of a biocide program set to dose on a weekly cycle:

- Start time:** 07:00
- Pre-Bleed:** 00h60m (ie. 07h00 to 08h00)
- Dose for:** 00h60m (ie. 08h00 to 09h00)
- Bleed L/O:** 04h00m (ie. 09h00 to 13h00)

Other Program Settings

- Setpoint** = 1000 TDS
- Pre Bleed Setpoint** = Setpoint – 13% (ie. 870 TDS)
- Bleed Lock-out Setpoint** = Setpoint + 50% (ie. 1500 TDS)
- Program** = 01
- Pump** = A
- Auxiliary Output On Timer** = 30m (i.e. delay off time after A dose)

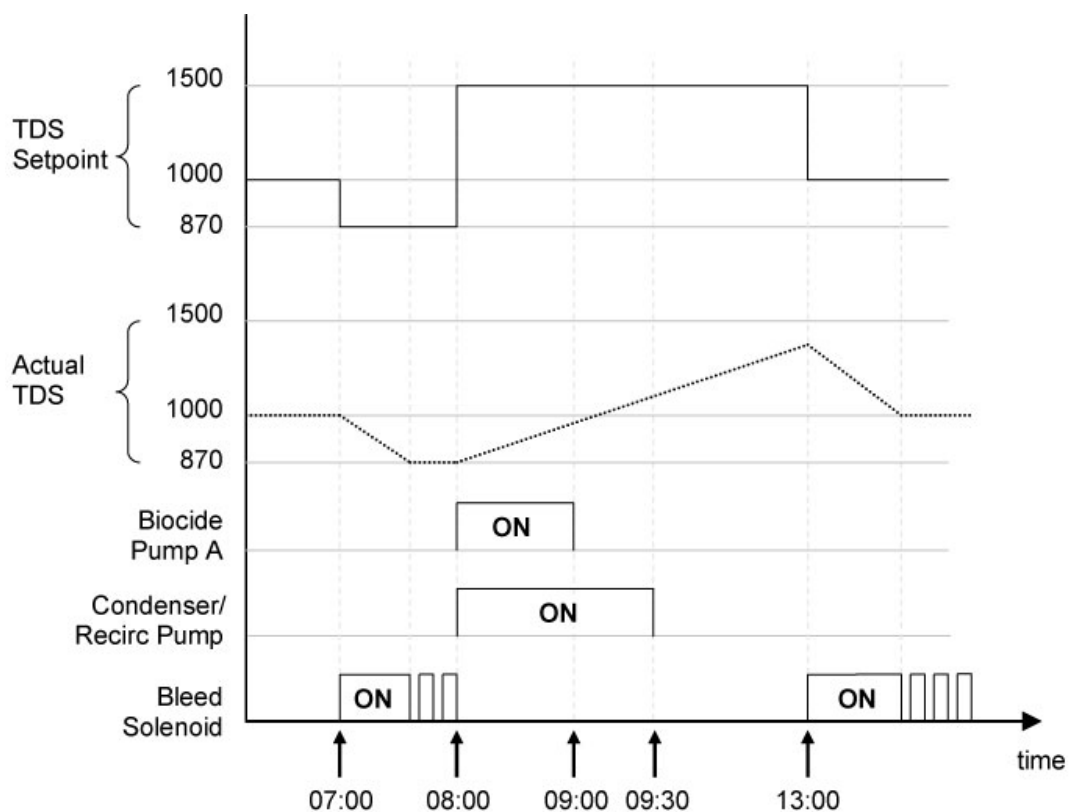

5.14 Flow Switch

Main Menu > SETUP MENU > GENERAL SETUP > FLOW SWITCH

Any or all of the outputs can be disabled when there is no flow. An output, when selected via this menu for flow detection, will stop immediately if no flow is detected. For example, when bleeding, the solenoid valve will close immediately if no flow is detected.

There are 3 possible settings in the menu for the flow switch:

- **DISABLE:** All outputs activate if required, regardless of flow or no flow
- **NORMAL:** Enabled outputs activate if required, only if the flow switch input is shorted
- **REVERSE:** Enabled outputs activate if required, only if the flow switch input is open circuit

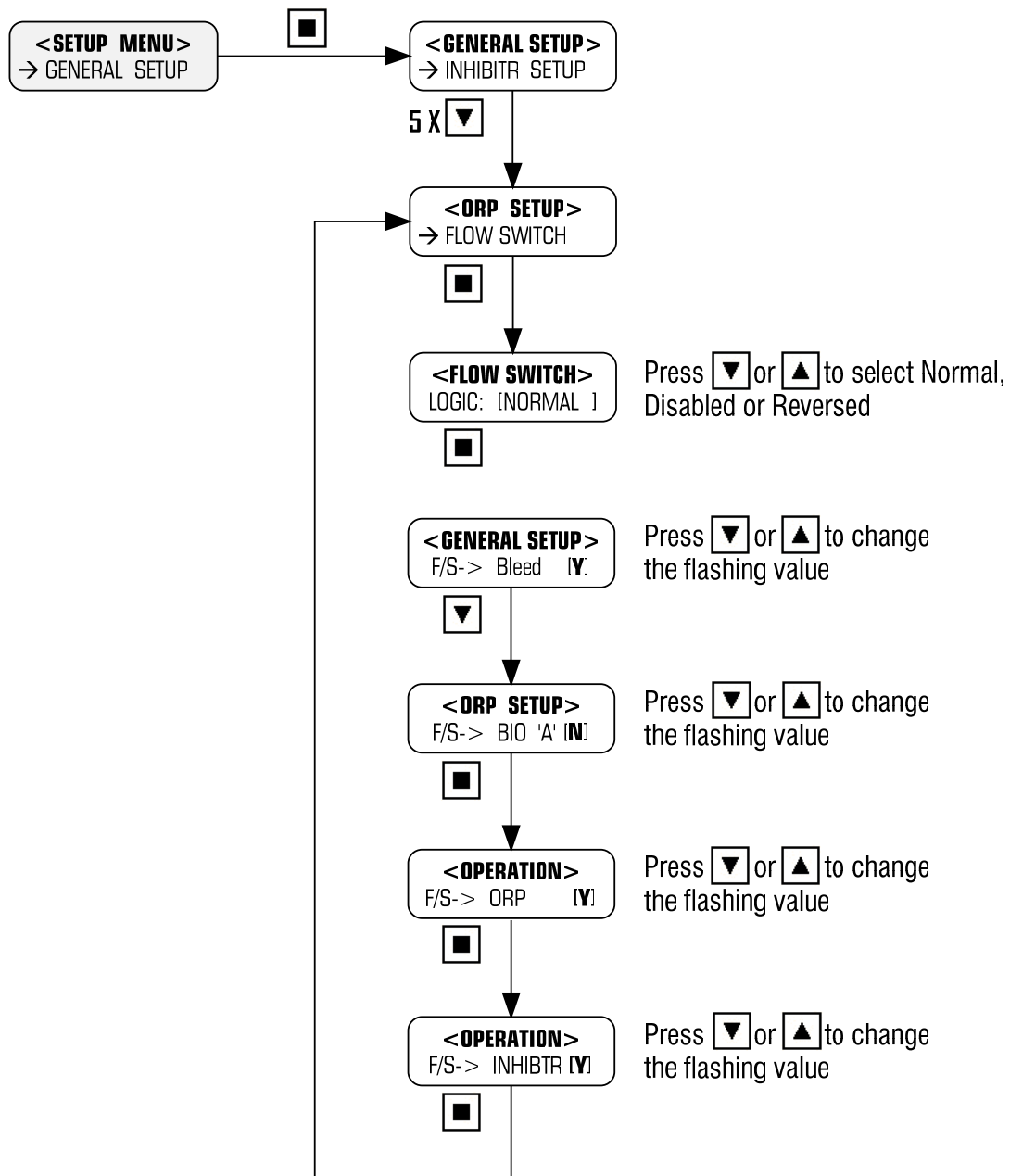

None, one, two, three or all four of the outputs can be selected to be disabled if there is no flow. Typically, the Bleed, ORP and Inhibitor outputs are disabled if there is no flow and the Biocide 'A' doses during its program regardless of the flow status. However the Biocide 'A' output can be set to be disabled if there is no flow.

5.15 Data Logging

Main Menu > SETUP MENU > GENERAL SETUP > DATA LOGGING

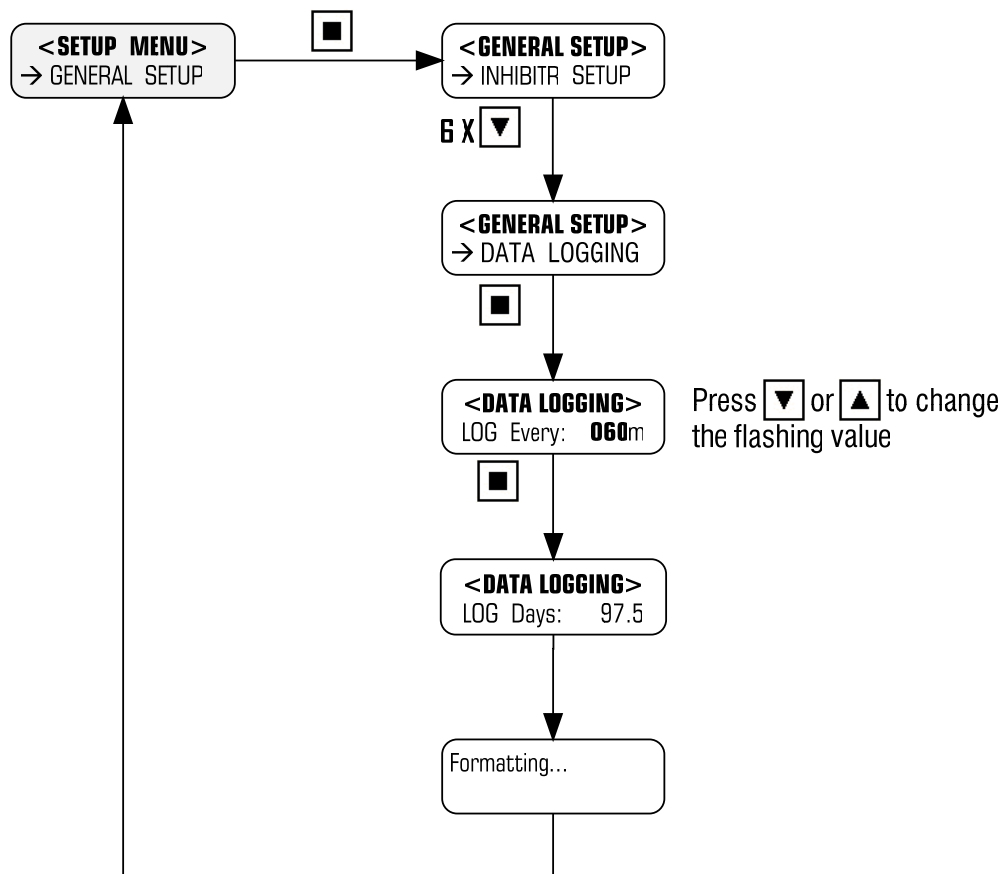

The controller has the facility to log the following items at the pre-programmed intervals:

- Date
- Time
- Conductivity reading (in TDS or μS)
- ORP reading (in mV)
- Temperature
- Percentage of time the Flow Switch was registering flow
- Percentage of time the Bleed Output was active
- Percentage of time the Inhibitor Pump was dosing
- Percentage of time the Biocide A Pump was dosing
- Percentage of time the ORP Pump was dosing
- Percentage of time the Common Alarm was activated

The pre-programmed intervals are 5, 10, 15, 30, 60, 120 or 240 minutes. If the controller is set to log every 0 minutes, then logging is disabled.

Each logged entry takes up memory, so the longer the interval, the longer the time can be between downloads. For example, the controller will have enough memory to store data for 8.1 days for a log taken every 5 minutes, 48.7 days for a log taken every 30 minutes, or for 390 days for a log taken every 240 minutes. Once the memory is full, the data logger loses the oldest information first.

The data is downloaded via the Comms port on the front panel of the controller. An optional cable is required, P/N SP-XP2-COMCABLE-USB-1, to perform a direct download to a pc or laptop.

6. Factory Settings

The default factory settings are outlined below. These are the settings programmed when a manual Factory Reset is initiated via the menu.

Menu Setting/Item	Default	Range
Units – Conductivity	TDS (ie ppm Total Dissolved Solids)	TDS or μ S
Bleed Setpoint	1000 ppm TDS	1 ppm – 9999 ppm
Conductivity Hysteresis	3%	1% - 90%
Conductivity Bleed Cycle	ON/OFF = 00s/00s (ie. Disabled)	00s/00s – 99s/99s
Units - ORP	mV (MilliVolts)	mV
ORP Control Setpoint	500mV	1 mV – 999 mV
ORP Operation	Oxidant	Oxidant or Reductant
ORP Control Method	Proportional	Proportional or On/Off
ORP Proportional Band	10%	1% - 90%
ORP Control Cycle	100s	10s – 100s
Inhibitor Mode	On bleed	On Bleed, Pulses, 24hr/Day
Inhibitor Duty Cycle	ON/OFF = 0050s/0050s (ie. On Bleed Only)	9999s/9999s
Biocide Programs	All programs disabled	N/A
Pre-Bleed Setpoint	Setpoint -15%	0% - 90%
Bleed Lockout Setpoint	Setpoint +20%	0% - 90%
Aux O/P On Timer	Biocide Dose + 000m	0m – 120m
Flow Switch Logic	Normal	Normal, Disable or Reverse
Outputs disabled on no flow *	Bleed, ORP & Inhibitor	Any combination of Bleed, Bio 'A' , ORP or Inhibitor

Data Logging	LOG Every: 000m (ie. Logging disabled)	0m, 5m, 10m, 15m, 30m, 60m, 120m or 240m
High Conductivity Alarm	0000 ppm TDS (ie. Disabled)	0 ppm – 9999 ppm
Low Conductivity Alarm	0000 ppm TDS (ie. Disabled)	0 ppm – 9999 ppm
Bleed Timer Alarm	Max Bleed: 000m (ie. Disabled)	0m – 999m
High ORP Alarm	0000 mV	0 mV – 999 mV
Low ORP Alarm	0000 mV	0 mV – 999 mV
Dose Timer Alarm	120m	0m – 999m
No Flow Alarm	Enable? [No]	Yes or No
Delay on Alarm	Trip Delay: 0008s	0s - 9999s

7. Specifications

Item	Specification
Power Supply	220-240VAC, 50/60Hz
Power Consumption	10W max (with no loads on outputs)
Inputs	Conductivity Probe (optional) ORP Sensor (optional) Ground probe (optional) Water meter volt-free contact (optional) Flow switch (optional, code AF04-3/4-NX-T)
Auxiliary Mains Output	240VAC continuous (2A fused)
Control Output	2A/250VAC (fused)
Alarm Relay Output	N/O & N/C (10A/250VAC resistive)
Condenser Pump (Aux) Relay Output	N/O (10A/250VAC resistive)
Flow Switch Repeat Output	N/O (10A/250VAC resistive)
Optional Outputs	4-20mA plus events (P/N AF10/10A-XP2) 4mA = 0 µS/TDS, 20mA = 5000 µS/TDS 4mA = 0 mV, 20mA = 1000 mV
Measured Conductivity Resolution	1µS / 1 ppm TDS
Measured ORP Resolution	1 mV
Accuracy	0.5% of measured range
Repeatability & drift	1.0% of measured range
Logged Items	Model Number, Software ver, No of log entries, Controller ID No, Date, Time, Conductivity, ORP, Temperature, Flow %, Bleed %, Inhibitor %, Biocide A %, Biocide B %, Alarm %
Data retention	100 years
Battery backup	1 year (approx)
Enclosure rating	IP55
Operating Temperature	0 - 50°C

8. Service & Technical Support

Important: Please note the serial number and product/system part number before calling for assistance.

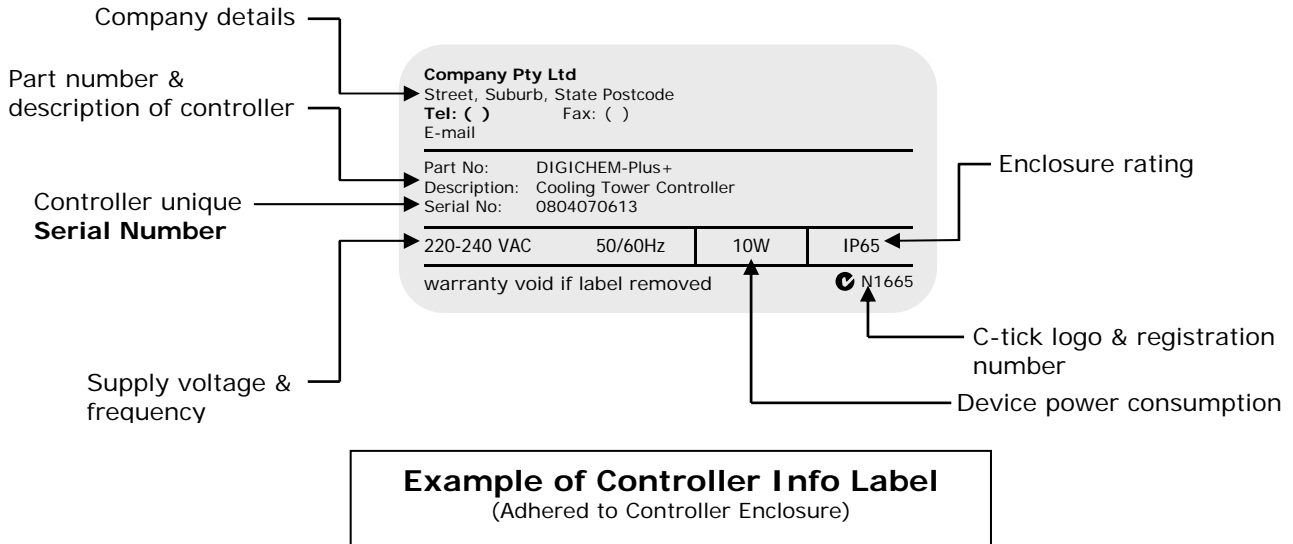

Note:

1. Controllers incorporated in a system, have the same serial numbers as the system itself.
2. The First 6 digits of serial is the date of manufacture (yymmdd)

9. Maintenance Schedule

The following table is the suggested maintenance schedule for the replacement of parts on a standard DIGICHEM-ORP-XP2 control system.

This schedule is based on relatively clean water in a cooling tower, with no adverse conditions or phenomenon occurring.

Item:	Description:	Suggested Maintenance:
SP-SK-01A-BK	Squeeze Tube for SEKO PE-1.3 & PE-0.4 Pumps	Check quarterly, replace after 12 Months
SP-DCON-P10AT-P	Conductivity Probe	Clean monthly, replace after 2 Years +
IONODE IH30-01M	ORP Probe	Clean monthly, replace after 1 Year +
SP-SOL-1/2-S	Solenoid Valve	Manually test monthly, replace as required
SP-SK-03A	Injection Valve	Replace as required
SP-TB0604B-020	Black Discharge Tubing	Replace as required
SP-DIGI-XP2-BAT	Controller Clock Backup Battery	Replace every 3 – 5 Years, replacement will need to be more frequent when there is regular power loss to the controller.
SP-TB0604N-PVC	Clear Suction Tubing	Replace as required